

ALWAYSE

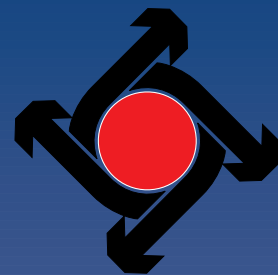

Ball Transfer Units



Catalogue 13



Ball table to be used in an assembly area.



Ball units used for air cargo handling.



Units installed into air cargo vehicle as part of a combined cargo handling system.



Die table for fast tool changes.



Ball units used for the assembly of heating units.

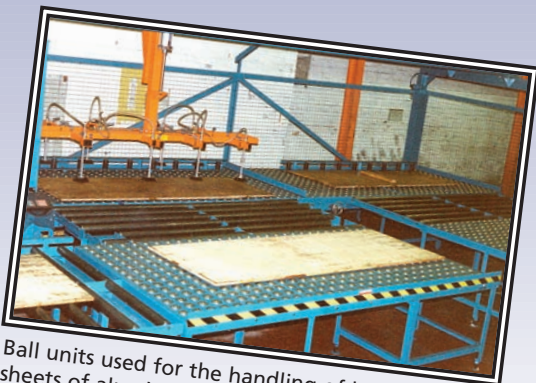

Ball units used for the handling of large sheets of aluminium.



Air cargo facility.



Airport cargo dolly/transfer.



ABB-Sweden.



Typical material handling system.

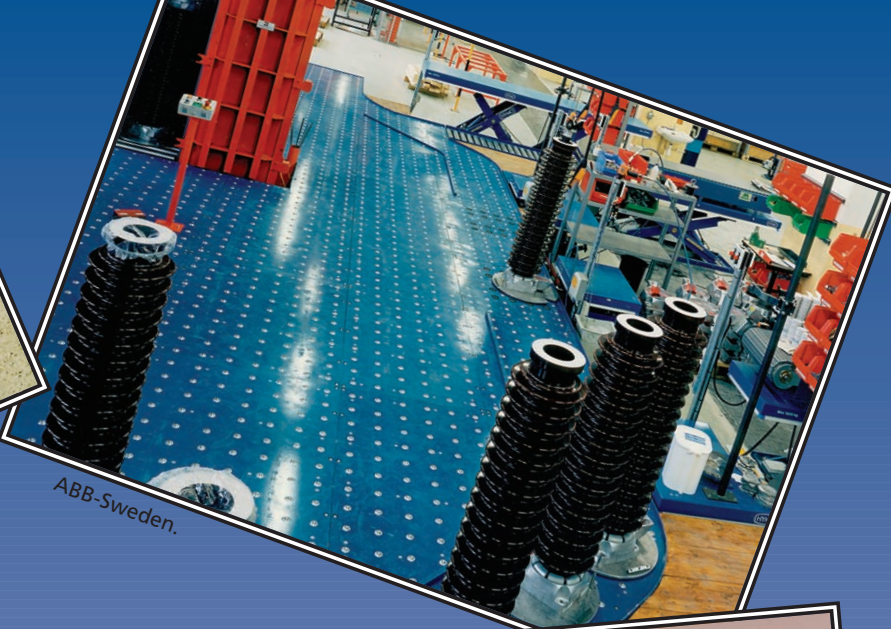
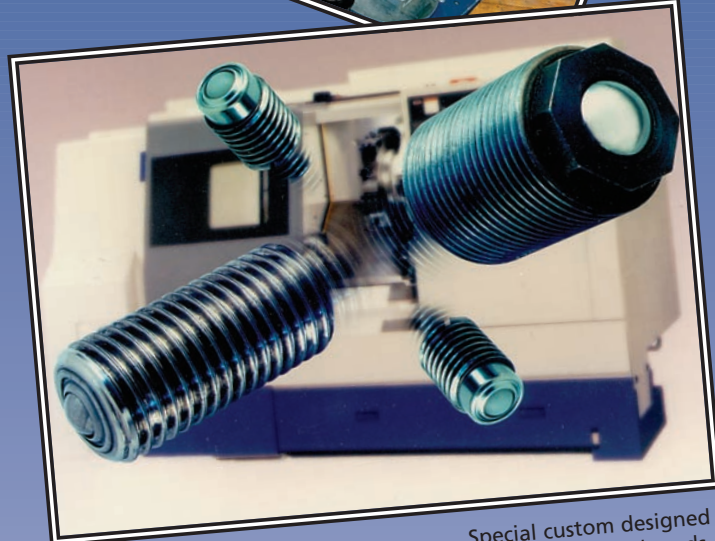

Special custom designed units with external threads.



Tilting ball table used in conjunction with gravity racking.



Live/dead ball tables to move and secure heavy items.



Specially designed assembly area.



Ball table with hinged section.



Resin transfer moulds in the aerospace industry.



DHL Heathrow.

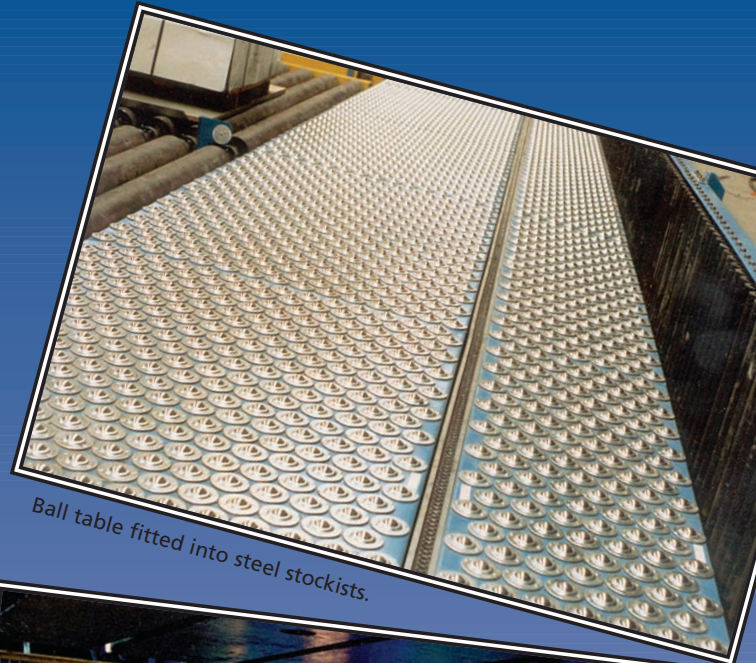

Ball table fitted into steel stockists.



Die/tool table designed, manufactured and installed at Premier Spring and Presswork.

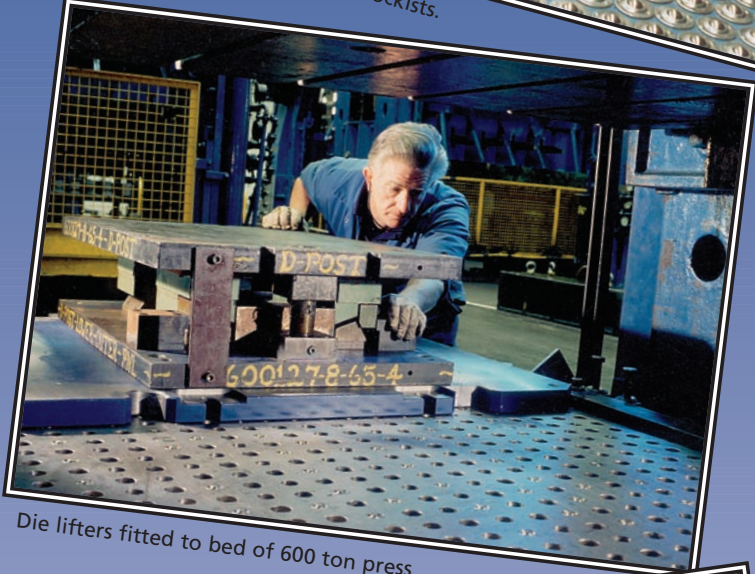

Die lifters fitted to bed of 600 ton press.



International material handling exhibition - Japan.



Special die table with slots for fork-lift truck forks.



Federal Express facility at Hong Kong International Airport.



Specialised ball stands.

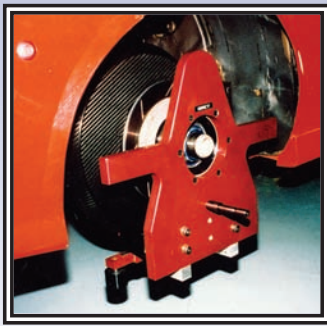

Special jig in use on saloon racing car.

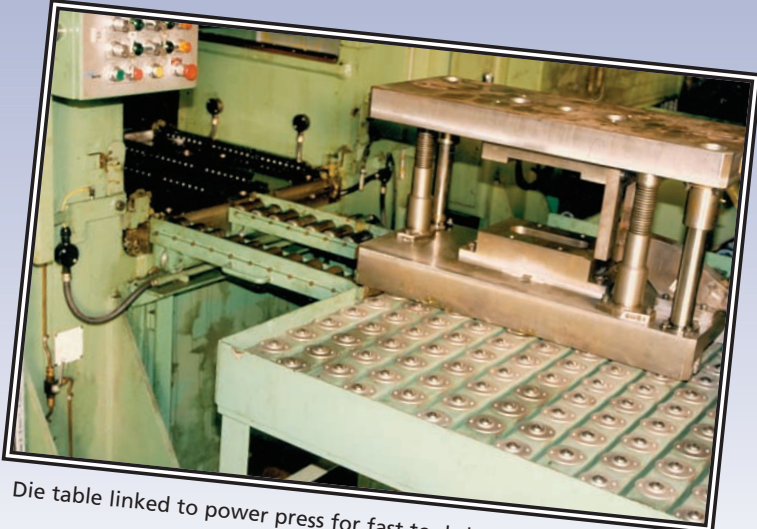

Die table linked to power press for fast tool changes.

ALWAYSE ENGINEERING LIMITED - TERMS AND CONDITIONS OF SALE

1 Interpretation

1.1 In these Terms Conditions:

"COMPANY" means Always Engineering Limited

"CONTRACT" means the contract for the purchase and sale of the Goods

"CUSTOMER" means the person or company who accepts a quotation of the Company for the sale of the Goods, or whose order for the Goods is accepted by the Company

"GOODS" means the goods which the Company is to supply in accordance with these Terms and Conditions

1.2 Any reference in these Terms and Conditions to any provision of a statute shall be construed as a reference to that provision as amended, re-enacted or extended at the relevant time.

2 Basis of the Sale

2.1 The Company shall sell and the Buyer shall purchase the Goods in accordance with any written quotation of the Company which is accepted by the Buyer within 60 days of its date, or any written order of the Buyer which is accepted by the Company, subject in either case to these Terms and Conditions, which shall govern this Contract to the exclusion of any other terms and conditions subject to which any such quotation is accepted or purported to be accepted, or any such order is made or purported to be made, by the Buyer.

2.2 No order submitted by the Buyer shall be deemed to be accepted by the Company unless and until confirmed in writing by the Company's authorised representative.

3 Price of the Goods

3.1 The price of the Goods shall be the Company's quoted price or, where no price has been quoted (or a quoted price is no longer valid), the price listed in the Company's published price list current at the date of delivery of the Goods

3.2 The Company reserves the right, by giving notice to the Buyer at any time before delivery, to increase the price of the Goods to reflect any increase in the cost to the Company which is due to any factor beyond the control of the Company.

3.3 The price is exclusive of delivery, handling, administration and packaging charges and any applicable value added tax, which the Buyer shall be additionally liable to pay to the Company.

4 Delivery

4.1 Unless otherwise provided in the Contract, delivery of the Goods shall be made by the Company at the Buyer's premises

4.2 The Contract price does not include the cost of off-loading and assembly, which shall be arranged by the Buyer and performed at its own expense and risk unless otherwise agreed in writing.

4.3 Any dates quoted for delivery of the Goods are approximate only and the Company shall not be liable for any delay in delivery of the Goods but shall use its reasonable endeavours to deliver on the quoted date. Time for delivery shall not be of the essence of the Contract

4.4 If the Buyer does not accept delivery when tendered by the Company the Buyer shall be liable for any storage, administration, carriage and re-delivery charges.

5 Risk and Property

5.1 Risk of damage to or loss of the Goods shall pass to the Buyer:

5.1.1 in the case of Goods to be delivered at the Company's premises, at the time when the Company notifies the Buyer that the Goods are available for collection; or

5.1.2 in the case of Goods to be delivered otherwise than at the Company's premises, at the time of delivery or, if the Buyer wrongfully fails to take delivery of the Goods, the time when the Company has tendered delivery of the Goods

5.2 Notwithstanding delivery and the passing of risk in the Goods, or any other provision of these Terms and Conditions, the property in the Goods shall not pass to the Buyer until the Company has received in cash or cleared funds payment in full of the price of the Goods and all other goods agreed to be sold by the Company to the Buyer for which payment is then due.

5.3 Until such time as the property in the Goods passes to the Buyer, the Buyer shall hold the Goods as the Company's fiduciary agent and bailee, and shall keep the Goods separate from those of the Buyer and third parties and properly stored, protected and insured and identified as the Company's property, but shall be entitled to resell or use the Goods in the ordinary course of its business providing that the proceeds of such sale shall be held upon trust for the Company. Where the Buyer does sell or pledge the Goods it shall hold the proceeds of sale or charging as fiduciary agent of the Company and forward the same to the Company upon a written request from the Company.

5.4 Until such time as the property in the Goods passes to the Buyer (and provided the Goods are still in existence and have not been resold), the Company shall be entitled at any time to require the Buyer to deliver up the Goods to the Company and, if the Buyer fails to do so forthwith, to enter upon any premises of the Buyer or any third party where the Goods are stored and repossess the Goods.

5.5 The Buyer shall not be entitled to pledge or in any way charge by way of security for any indebtedness any of the Goods which remain the property of the Company, but if the Buyer does so all moneys owing by the Buyer to the Company shall (without prejudice to any other right or remedy of the Company) forthwith become due and payable.

6 Limitation of Liability

6.1 All warranties, conditions or other terms employed by statute or common law are excluded to the fullest extent permitted by law.

6.2 Any claim by the Buyer which is based on any defect in the quality or condition of the Goods or their failure to correspond with specification shall (whether or not delivery is refused by the Buyer) be notified to the Company within 7 days from the date of delivery or (where the defect or failure was not apparent on reasonable inspection) within 2 months after delivery of the Goods. If delivery is not refused, and the Buyer does not notify the Company accordingly, the Buyer shall not be entitled to reject the Goods and the Company shall have no liability for such defect or failure, and the Buyer shall be bound to pay the price as if the Goods had been delivered in accordance with the Contract.

6.3 Where any valid claim in respect of any of the Goods which is based on any defect in the quality or condition of the Goods or their failure to meet Company specification is notified to the Company in accordance with these Terms and Conditions, the Company shall be entitled to replace the Goods (or the part in question) free of charge or, at the Company's sole discretion, refund to the Buyer the price of the Goods (or a proportionate part of the price), but the Company shall have no further liability to the Buyer.

6.4 Except in respect of death or personal injury caused by the Company's negligence, the Company shall not be liable to the Buyer by reason of any representation (unless fraudulent), or any implied warranty, condition or other term, or any duty at common law, or under the express terms of the Contract, for any indirect, special or consequential loss or damage (whether for loss of profit or otherwise), costs, expenses or other claims for compensation whatsoever (whether caused by the negligence of the Company, its employees or agents or otherwise) which arise out of or in connection with the supply of the Goods or their use or resale by the Buyer, and the entire liability of the Company under or in connection with the Contract shall not exceed the price of the Goods, except as expressly provided in these Terms and Conditions.

6.5 The Company shall have no liability whatsoever where the Goods have not been maintained or used in accordance with their recommended specifica-

tions and maintenance schedules as updated from time to time by the Company.

6.6 The Seller shall not be liable for any delay or failure attributable to any cause beyond the Seller's reasonable control including without limitation fire, strike, act of god and embargo.

7 Terms of Payment

7.1 The Buyer shall pay the price of the Goods in pounds sterling (without any deduction) within 30 days of the date of the Company's invoice, and the time of payment of the price shall be of the essence of the Contract.

7.2 If the Buyer fails to make any payment on the due date then, without prejudice to any other right or remedy available to the Company, the Company shall be entitled to:

7.2.1 cancel the Contract or suspend any further deliveries to the Buyer;

7.2.2 appropriate any payment made by the Buyer to such of the Goods (or the goods supplied under any other contract between the Buyer and the Company) as the Company may think fit; and

7.2.3 charge the Buyer interest (both before and after any judgement) on the amount unpaid, at the rate of 3 per cent per annum above Barclays Bank Plc base rate from time to time, until payment in full is made (a part of a month being treated as a full month for the purpose of calculating interest).

7.2.4 set of any monies due to the Buyer on any account whatsoever against monies due to the Buyer from the Company

7.3 Where the Company agrees to invoice in a currency other than sterling the Buyer shall be liable for all currency conversion brokerage or other charges and ensure that the sum payable to the Company when converted to pounds Sterling is not less than the amount payable in pounds sterling on the date of quotation

8 Insolvency of Buyer

8.1 This clause applies if:

8.1.1 the Buyer makes any voluntary arrangement with its creditors or (being an individual or firm) becomes bankrupt or (being a company) becomes subject to an administration order or goes into liquidation (otherwise than for the purposes of amalgamation or reconstruction); or

8.1.2 an encumbrancer takes possession, or a receiver is appointed, of any of the property or assets of the Buyer; or

8.1.3 the Buyer ceases, or threatens to cease, to carry on business; or

8.1.4 there is a change in control of the ownership of the Company or its shares

8.1.5 the Company reasonably apprehends that any of the events mentioned above is about to occur in relation to the Buyer and notifies the Buyer accordingly.

8.2 If this clause applies then, without prejudice to any other right or remedy available to the Company, the Company shall be entitled to cancel the Contract or suspend any further deliveries under the Contract without any liability to the Buyer, and if the Goods have been delivered but not paid for, the price shall become immediately due and payable notwithstanding any previous agreement or arrangement to the contrary.

9 General

9.1 No waiver by the Company of any breach of the contract by the Buyer shall be considered as a waiver of any subsequent breach of the same or any other provision.

9.2 This Contract shall be governed by the laws of England, and the Buyer agrees to submit to the non-exclusive jurisdiction of the English courts.

ALWAYSE

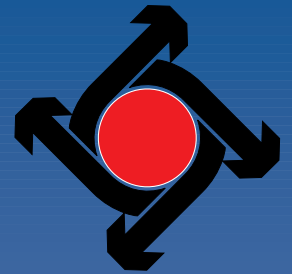

Ball Transfer Units

Alwaysse Engineering Limited
Miller Street Birmingham B6 4NF
England

Telephone: 0121 380 4700
(International): 44 121 380 4700

Fax: 0121 380 4701
(International): 44 121 380 4701

Home page: www.alwaysse.net
E-mail: sales@alwaysse.co.uk

FREE Technical Advice:

We offer a free technical advice service - if you are unsure of the correct ball unit to use, ask us. We do not accept liability for the choice of unit if we are not consulted.



Alwaysse Engineering Limited

Alwaysse Engineering was established in 1939 when a small engineering company, Sheridan Tools, was purchased. Later its name was changed to "Alwaysse" meaning that the units are multi-directional and move in all directions or ways - hence "Alwaysse". The distinctive spelling adds to the company's individuality.

The present chairman, Mr L.W. Pinnick, has overseen its growth and development since the late 1940s.

Alwaysse Ball Transfer Units are used as part of a conveyor or material handling system to enable loads both light and heavy, to be moved or trans-

ferred in any direction. As the originators of the Ball Transfer Unit over 50 years ago, we have become an important part of the material handling industry.

Whether ball units are used for loading/feeding machines, moving goods/materials, as an alternative to a castor, or in a form of linear operation, they have become an integral part of industry and provide an important and essential service.

Alwaysse Ball Units are used in all industries throughout the World and over 2,000,000 are sold every year.

TECHNICAL INFORMATION

DESIGN & CONSTRUCTION

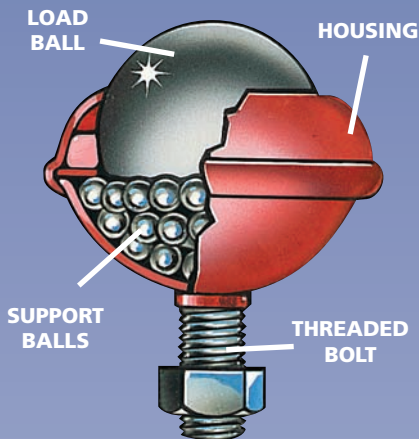

Alwaysse ball units are a multi-directional, material handling system, manufactured from high quality materials in our Birmingham factory.

They consist of a large load-bearing ball which sits upon many small balls encapsulated in a hemi-spherical cup. The housing can contain a seal to clean the load ball as it rotates. The design greatly reduces friction and allows heavy loads to be moved with a minimum of effort.

Our ball units may be used at any orientation but deviation from the vertical may result in a reduction in the stated load ratings quoted in this catalogue.

FIXING METHODS

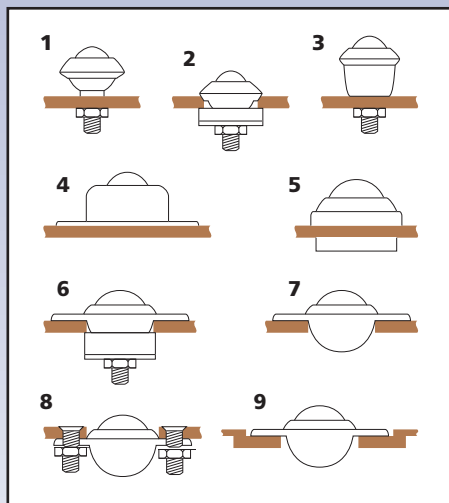

There are various methods of fixing Alwaysse ball units. A wide range of fittings enable them to be used with various different materials.

Fixing clips are available for most designs - see pages 28 & 29.

MATERIALS

Type	Load Ball	Support Balls	Housing
13	Carbon Steel 60-66RC	Carbon Steel 60-66RC	Carbon Steel Bright Zinc Plated
14	Nylon 66	Carbon Chrome 60-66RC	Carbon Steel Bright Zinc Plated
15	Stainless Steel AISI 420 52-58RC	Stainless Steel AISI 420 52-58RC	Stainless Steel AISI 304 SelfColour
16	Stainless Steel AISI420 52-58RC	Stainless Steel AISI 420 52-58RC	Carbon Steel Bright Zinc Plated

Alwaysse ball units are available in various materials. The material required for your ball units should be quoted when ordering - see page 3 for ordering details.

Lubrication

Each unit is pre-lubricated during manufacture and normally does not require further attention. In certain instances we will advise on lubrication. Greasing or oil points can be incorporated in some units.

Cleaning

A suitable cleaning or release fluid should be used in dirty conditions. For washing, a suitable detergent such as paraffin, for freeing, a suitable agent such as WD40 - please consult technical support.

Most designs have dirt exit holes incorporated in the bearing cup, or these can be added on request.

Shock Loads

When calculating loads, consider the possibility of impact caused by incorrect levels. Spring loaded units will reduce wear and tear if there are regular shock impacts. Shock loading can also be reduced by fitting compressible pads.

Ball units can also be made retractable by other means, such as pneumatic or hydraulic cylinders, cams or levers. They can be programmed to operate in sequence. All stated loads in the catalogue are dynamic loads.

Self Levelling

Can be achieved by fitting rubber pads. This reduces excessive loads on just a few units. Details on request.

Temperature Range

Min. -30°C to max. +70°C continuous, or +100°C intermittent. Special seals may need to be fitted to suit extreme conditions. In clean conditions and without seals +150°C to +200°C are possible, using Type 15 units at reduced loads.

Conveying Speed

Maximum recommended conveying speed is 1 metre per second for steel load balls and 0.25 metres per second for nylon.

Seals

These help resist ingress of dirt and swarf. They can be omitted on request. Woollen felt seals fitted as standard.

Breakaway Coefficient of Friction

The average breakaway friction for new ball units containing steel balls in a good working environment is 0.01 to 0.015 (1% to 1.5% of the load) and 0.02 to 0.025 (2% to 2.5%) for units with felt seals.

BALL TABLES

Red arrows indicate ideal movement.

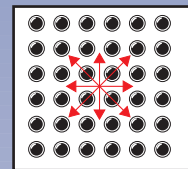

Square Pitch

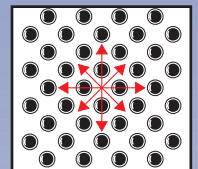

Diamond Pitch

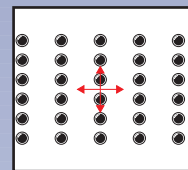

Elongated Pitch

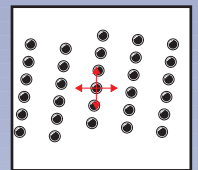

Elongated Diagonal Pitch

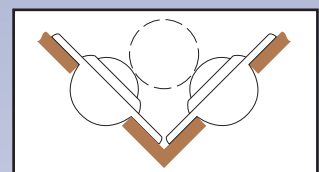

Vee location

QUANTITY CALCULATION

The weight of the article to be conveyed should be divided by 3. The result will give the maximum load any single ball will bear.

On any accurately levelled or flexible surface, a number greater than 3 may be used. The surface hardness and condition of the article should be considered to avoid ball unit penetration.

Spacing

The pitch is calculated by dividing the narrowest dimension by 3.5, i.e. if the narrowest dimension is 350mm divided by 3.5=100mm pitch between ball centres. This ensures 3 ball units are always beneath the narrowest dimension of the load at any one time.

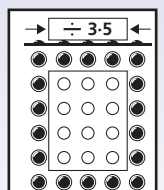

APPLICATIONS

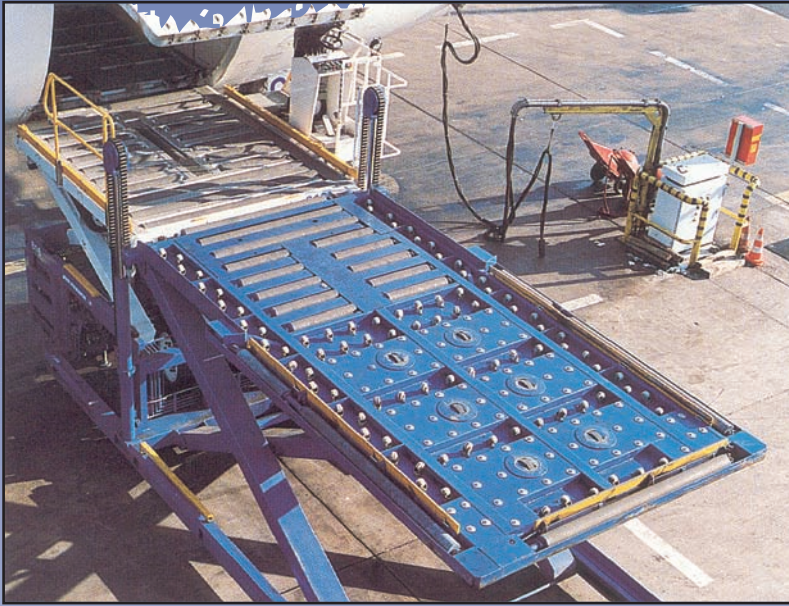

There are many possible applications for Alwaysse ball transfer units, where loads need to be moved smoothly, precisely and with minimum effort in any direction.

Some typical applications include cargo and baggage handling

(shown above), assembly lines, as a castor, machine loading, sliding-door systems, machine tables, etc.

Alwaysse not only advise and supply ball units, but also regularly design and manufacture complete assemblies ready for customers to use.

QUALITY

Alwaysse Engineering Limited have a policy of continually improving the product range with new innovative and creative ideas using the latest CNC machinery and production/inspection methods.

Our specially designed ball unit test machine, regularly used to test production units, together with many years of research and experience, ensures world-class performance.

ORDERING PROCEDURE

Alwaysse provide a completely free technical advice service. We can help you select not only the most suitable ball unit for your application, we can advise on every aspect of layout, design, manufacture and maintenance of your installation.

We strongly recommend you take advantage of this service.

To Order

1) It is generally only necessary to quote the Product Reference Number (i.e. 1009, 1019 or 530-0) and the Material Type (i.e. Type 13, 14, 15 or 16).

2) There are however instances where more information is required.

a) Where applicable the length of thread (dimension N) and the spring washer diameter (dimension W), see pages 6-7 & 10-11, also need to be indicated, e.g. 3001-13-25 and 3004-13-16.9.

b) Also, if applicable, quote the special specification code. For example,

- NO (no oil)
- NS (no seal)
- NB (nylon ball)
- PB (phenolic load ball)
- DE (dirt exit hole)
- SI (solid steel inner ring).

Black phenolic balls are available in $\varnothing 19\text{mm}$ and $\varnothing 25.4\text{mm}$ load balls only.

QUICK GUIDE TO THE PRODUCT RANGE

Pages 4,5

Flange Fixing Units

Pages 6,7

Thread Fixing Units

Pages 8,9

Tube Fixing-Clamp Fixing-Miscellaneous Units

Pages 10,11

Base Fixing Units

Pages 12,13

Mini ball transfer units, ball stands, hangerbolts

Pages 14,15

Glide-Alwaysse Units & Fixing Sockets

Pages 16,17

Euro Units

Pages 18,19

Heavy Duty Units, Series 800

Pages 20,21

Hi-Tech, Double Seal, Units

Pages 22,23

Hevi-Load Units 0,1,2 & 3

Pages 24,25

Hevi-Load Units 5,6 Die Lifters

Pages 26,27

Spring Loaded Units

Pages 28,29

TUFF Series Heavy Duty Units

Pages 30,31

Fixing Clips

Page 32

Tee Blocks, Die Tables



FLANGE FIXING UNITS

3016 - 4001

Features: General purpose. Low profile, dirt exit hole. No seals on 3016 and 3025 units.

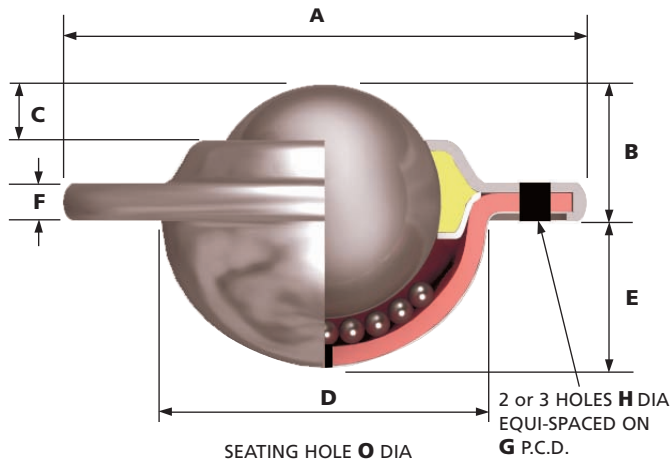

Ball unit Ref. No's 1022 and 1035 with solid steel inner ring (SI) option illustrated with no seal for improved protection from shock loading.

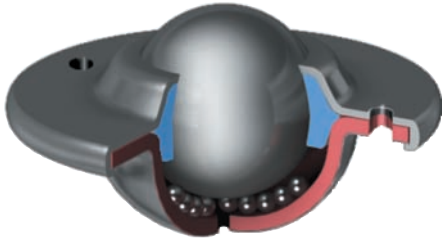

1502

Features: Low profile, high load capacity. Plastic knife edge seal on load ball. Dirt exit hole. Requires 5mm radius on fixing hole. See 'R'.

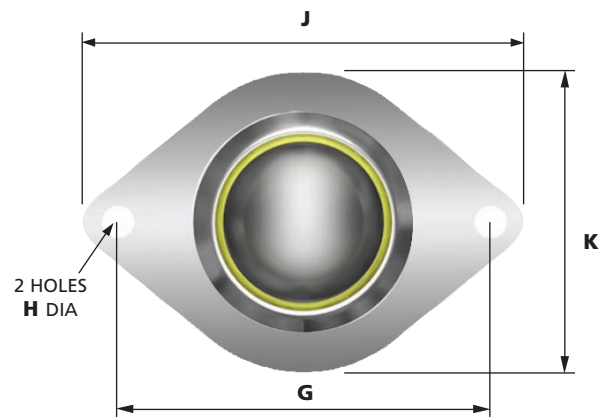
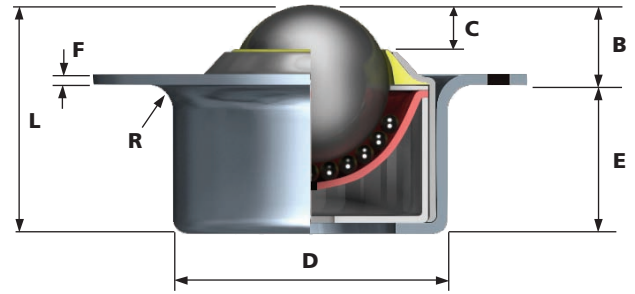

1010 / 1030

Features: Press ball unit into hole to fix, prise out to remove. Units can either be fixed or replaced quickly. Low profile, dirt exit hole.

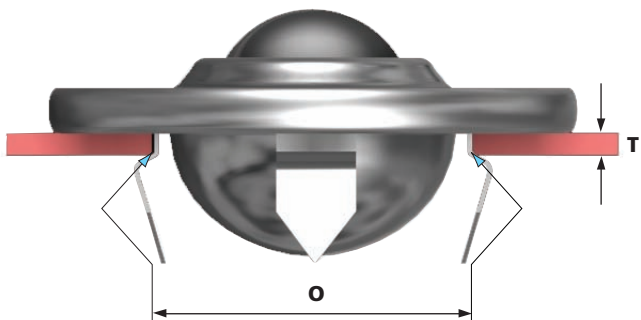
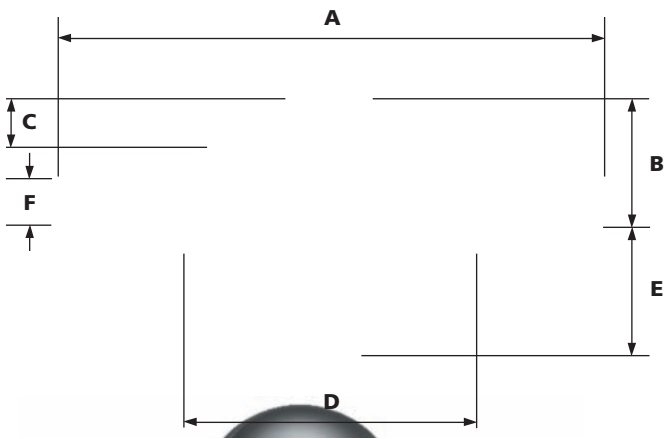

2002 XTRA - TUF

Features: Heavy duty construction, designed for arduous and dirty conditions. Flushing hole for cleaning, extra large dirt exit hole.

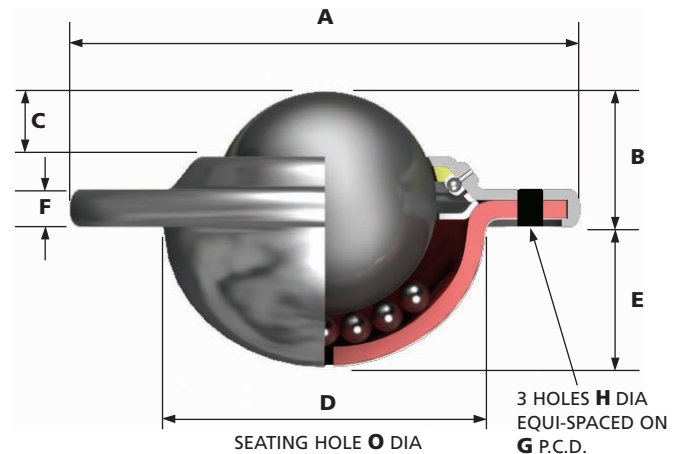

3 HOLES FOR HEAVY DUTY FIXING

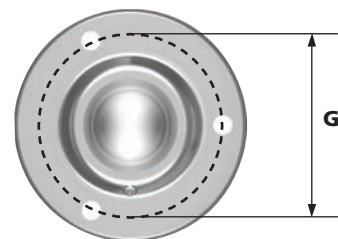

REF No.	FIXING HOLES	BALL SIZE (mm)	WEIGHT (KGS)	DIMENSIONS (mm)								
				A	B	C	D	E	F	G	H	O
3016	2	15.8	0.045	41.3	10.2	4	22.2 ±0.2	8.3	3.2	30 ±0.2	3.5	23
3000	2	19	0.087	61	10	3.2	29.1 ±0.2	12	3.2	44.5 ±0.2	5.1	30
3006	3											
3025	2	25.4	0.135	56	14.6	7.3	34.7 ±0.2	14.6	4	45.5 ±0.2	4.5	35.5
1000	2	25.4	0.175	73	14.2	6.3	37.2 ±0.2	15.8	3.5	55.6 ±0.2		38.1
1008	3											
1022	3	31.7	0.265	73.7	16.2	8	45.5 ±0.2	19.9	4.2	58.7 ±0.2		46.5
1035	2											
32742	2	31.7	0.270	73.7	16.2	8	45.5 ±0.2	19.9	4.2	58.7 ±0.2	5.1	46.5
32743	3											
2000	2	39.7	0.515	89	21.4	8.7	55.6 ±0.2	24.6	6	70 ±0.2	7	56.5
2011	3											
4001	3	50.8	1.065	120.7	28.3	14.3	75.3 ±0.2	30.2	6.3	92 ±0.2	8	76.5

MAXIMUM DYNAMIC LOADING (kg)							
TYPE 13		TYPE 14		TYPE 15		TYPE 16	
Carbon Steel Bearings, Zinc Plated Pressings		Nylon Load Bearing, Zinc Plated Pressings		Stainless Steel Bearings and Pressings		Stainless Steel Bearings, Zinc Plated Pressings	
LOAD UP	LOAD DOWN	LOAD UP	LOAD DOWN	LOAD UP	LOAD DOWN	LOAD UP	LOAD DOWN
12	6	8	4	12	6	12	6
25	10	20	10	25	10	25	10
55	25	25	10	55	25	55	25
125	55	25	10	125	55	125	55
140	60	N/A	N/A	140	60	140	60
340	100	N/A	N/A	250	100	340	100

The 32742 and 32743 ball units have 7 dirt exit holes for removal of dirt and debris and no seal

DIMENSIONS (mm)												
B	C	D	E	F	G	H	J	K	L	R		
Working Height of Ball	Ball Exposure above Outer Ring	Body Diameter	Under Flange to Base	Flange Thickness	P.C.D. or Centres of Fixing Holes	Hole Diameter of Fixing Holes	Major Flange Size	Minor Flange Size	Overall Height	Radius Under Flange		

1502	2	25.4	0.196	12	6	42 ±0.2	24.5	1.7	58.7 ±0.2	5.1	69.1	50	36.5	5
------	---	------	-------	----	---	---------	------	-----	-----------	-----	------	----	------	---

100	50	25	10	100	50	100	50
-----	----	----	----	-----	----	-----	----

DIMENSIONS (mm)										
A	B	C	D	E	F	G	H	O	T	
Max Diameter	Working Height of Ball	Ball Exposure above Outer Ring	Body Diameter	Under Flange to Base	Flange Thickness	P.C.D. or Centres of Fixing Holes	Hole Diameter of Fixing Holes	Seating Hole Diameter	Table Top Thickness	

1010	-	25.4	0.195	73	15.4	6.3	36.8 ±0.2	15	4.8	N/A	N/A	50	5
1030	-	31.7	0.275	73.7	17	8	44.6 ±0.2	19.5	5	N/A	N/A	50	5

55	25	25	10	55	25	55	25
125	55	25	10	125	55	125	55

DIMENSIONS (mm)									
A	B	C	D	E	F	G	H	O	
Max Diameter	Working Height of Ball	Ball Exposure above Outer Ring	Body Diameter	Under Flange to Base	Flange Thickness	P.C.D. or Centres of Fixing Holes	Hole Diameter of Fixing Holes	Seating Hole Diameter	

2002	3	39.7	0.635	94.6	21.2	6.9	62 ±0.2	27.3	6.3	76.2 ±0.2	7	63.3
------	---	------	-------	------	------	-----	---------	------	-----	-----------	---	------

225	100	N/A	N/A	225	100	225	100
-----	-----	-----	-----	-----	-----	-----	-----

To order, specify REF N° and TYPE, i.e. 3016-13.

General Tolerance unless stated ±0.3mm

THREAD FIXING UNITS

3001

Features: Adjustable height, drilled hole fixing.
Optional extras: Additional nuts, alternative thread sizes, dirt exit hole.

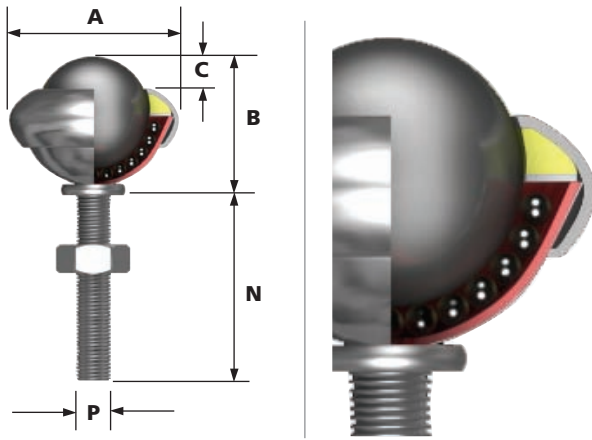

3002

Features: Large support area, greater stability, drilled hole fixing.
Optional extras: Alternative thread sizes, dirt exit hole.

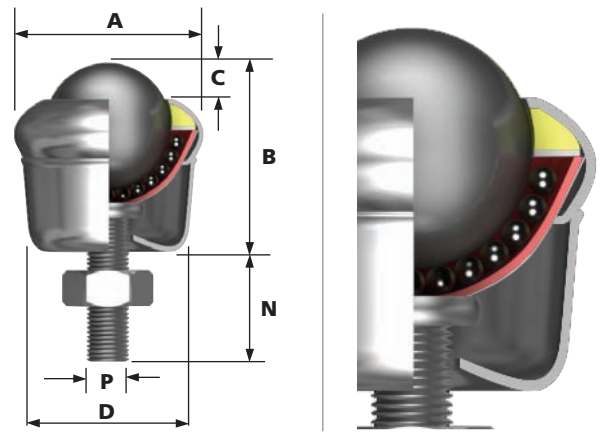

1003

Features: Large support area, greater stability, drilled hole fixing.
Optional extras: Alternative thread sizes, dirt exit hole.

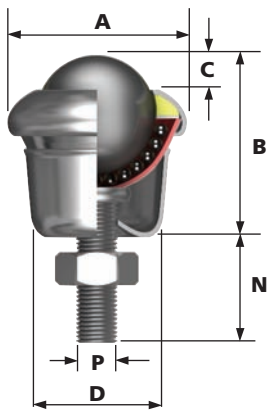

1009

Features: Adjustable height, drilled hole fixing.
Optional extras: Additional nuts, alternative thread sizes, dirt exit hole.

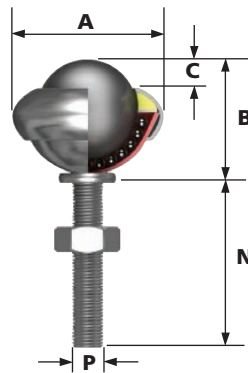

1501

Features: Large support area, greater stability, drilled hole fixing. High load capacity, plastic knife edge seal on main ball.
Optional extras: Alternative thread sizes, dirt exit hole.

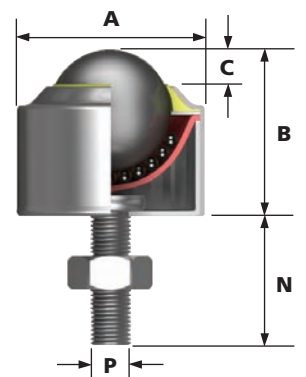

2001

Features: Adjustable height, drilled hole fixing.
Optional extras: Additional nuts, alternative thread sizes, dirt exit hole.

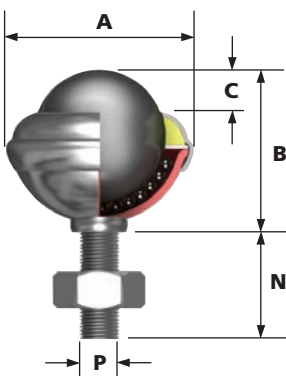

2005

Features: Large support area, greater stability, drilled hole fixing.
Optional extras: Alternative thread sizes, dirt exit hole.

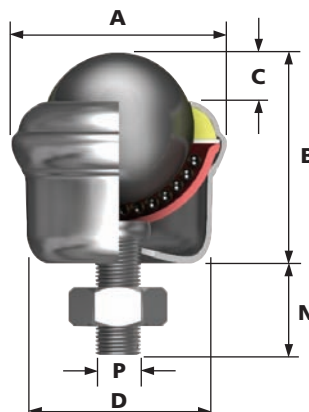

4004

Features: Adjustable height, drilled hole fixing. High load capacity, dirt exit hole. Can be dismantled for cleaning.
Optional extras: Grease points can be fitted. Alternative thread sizes.

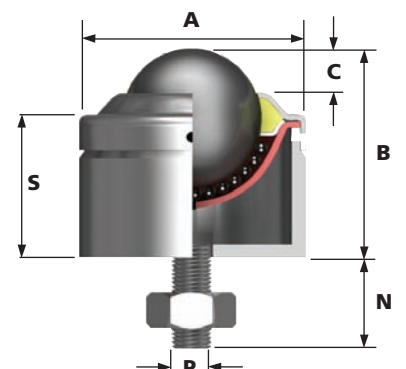

REF No.	BALL SIZE (mm)	MAX TORQUE on NUT (Nm)	WEIGHT (KGS)	DIMENSIONS (mm)						MAXIMUM DYNAMIC LOADING (kg)							
				A	B	C	D	N	P	TYPE 13 Carbon Steel Bearings, Zinc Plated Pressings		TYPE 14 Nylon Load Bearing, Zinc Plated Pressings		TYPE 15 Stainless Steel Bearings and Pressings		TYPE 16 Stainless Steel Bearings, Zinc Plated Pressings	
				Max Diameter	Working Height of Ball	Ball Exposure above Outer Ring	Body Diameter	Length of Thread	Thread Sizes	LOAD UP	LOAD DOWN	LOAD UP	LOAD DOWN	LOAD UP	LOAD DOWN	LOAD UP	LOAD DOWN

3001	19	15	0.060	32.1	24.6	4.7	-	25 30 35 40 50	M8	25	10	20	10	25	10	25	10
3002			0.080		30.2		25.4	18-23-28 33-43									

Ball units are also available with black phenolic load balls (see page 3 suffix PB) of \varnothing 19mm and \varnothing 25.4mm. Ball transfer units assembled with a black phenolic load ball can be used for glass handling applications.

20-25-30-45

1003	25.4	15	0.160	39.7	6.3	25.4	18 23 28 33 43	M8	55	25	25	10	55	25	55	25
1009			0.140				32.5		-	25 30 35 40 50						
1501			0.180	39.5	35.8	6.1	-		18 23 28							

*Pattern 4004 can be supplied with other screw sizes or plain shanks.

REF No.	BALL SIZE (mm)	MAX TORQUE on NUT (Nm)	WEIGHT (KGS)	DIMENSIONS (mm)							MAXIMUM DYNAMIC LOADING (kg)							
				A	B	C	D	N	P*	S	TYPE 13 Carbon Steel Bearings, Zinc Plated Pressings		TYPE 14 Nylon Load Bearing, Zinc Plated Pressings		TYPE 15 Stainless Steel Bearings and Pressings		TYPE 16 Stainless Steel Bearings, Zinc Plated Pressings	
				Max Diameter	Working Height of Ball	Ball Exposure above Outer Ring	Body Diameter	Length of Thread	Thread sizes	Base to top of body	LOAD UP	LOAD DOWN	LOAD UP	LOAD DOWN	LOAD UP	LOAD DOWN	LOAD UP	LOAD DOWN
2001	39.7	20	0.400	55.5	47.62	11.9	-	25 30 40 50	M10	-	140	60	N/A	N/A	140	60	140	60
2005			0.460	55.5	54.8		49	22 32 42										
4004	50.8	25	1.720	89	76	14.3	-	UPTO 75	5/8" Whit M16	53.8	340	100	N/A	N/A	250	100	340	100

To order, specify REF No., TYPE and LENGTH OF THREAD, i.e. 3001-13-25.

General Tolerance unless stated \pm 0.3mm

TUBE FIXING • CLAMP FIXING • MISCELLANEOUS UNITS

3004 • 1002 TUBE FIXING

Features: Tube fixing is achieved by pushing the spring washer into a suitable size tube and turning to lock. 3 sizes available - see dimension 'W'. Suitable for use as a castor.

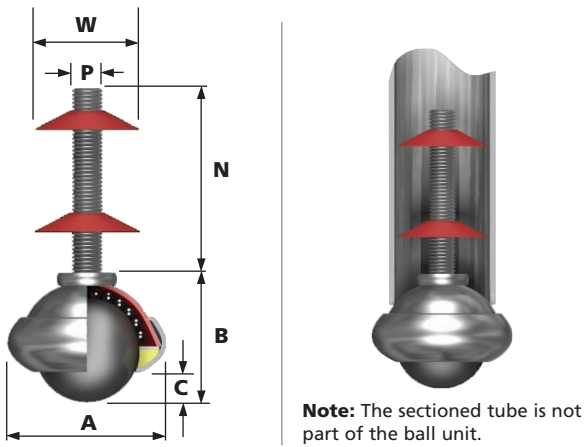

2004 TUBE FIXING

Features: Tube fixing is achieved by pushing the bush into the tube. Rotating the unit expands the rubber bush for an interference fit. Excellent as a castor.

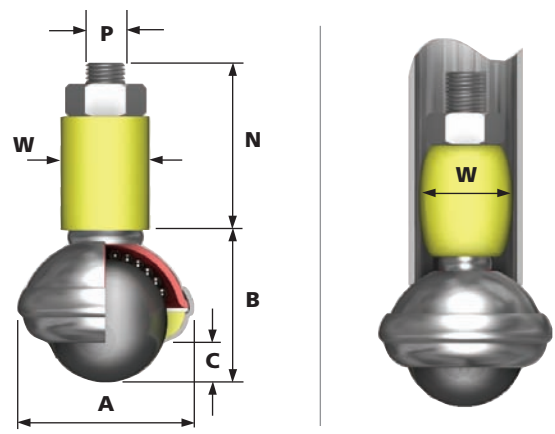

3007 • 1001 • 1021 CLAMP FIXING

Features: The 3007 and 1001 can be fixed to 1mm-10mm thick materials. 1mm-27mm thick materials for the 1021. The maximum tightening torque is 15Nm for the 3007 and 1001, 20Nm for the 1021. Optional extras: Dirt exit hole.

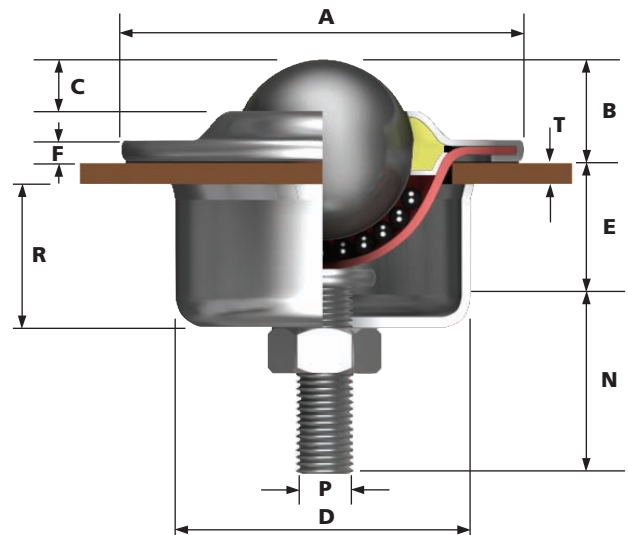
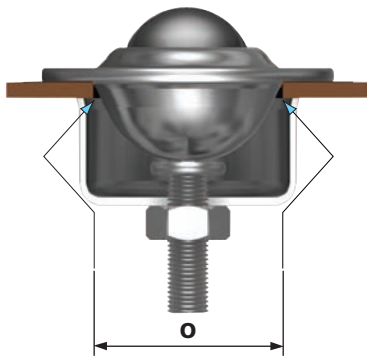

1004

Features: Supplied with circlip for loosely fixing to materials up to 6.4mm thick. Dirt exit hole.

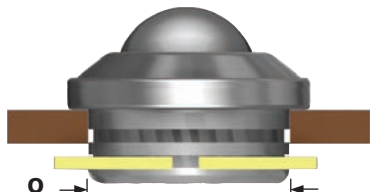
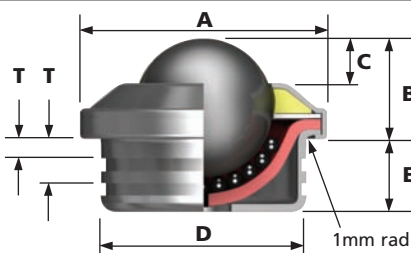

1007

Features: Small taper on body allows for interference fixing. Do not strike the ball, use a tube on the flange diameter when fixing. Approx size of taper is 35.8mm top and 35.4mm bottom. Dirt exit hole.

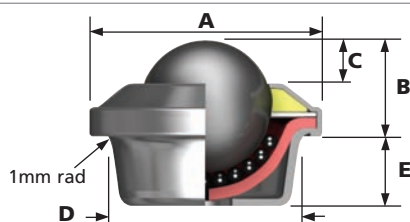

1500

Features: High load capacity. Improved plastic knife edge seal wipes debris off outside the ball. Dirt exit hole.

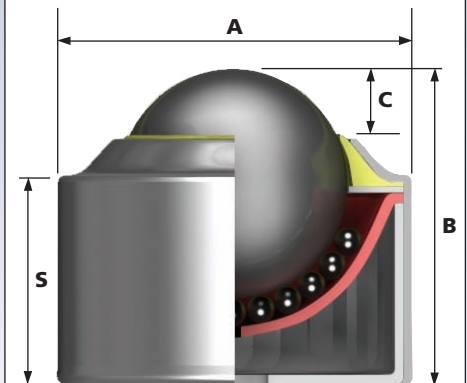

REF No.	BALL SIZE (mm)	WEIGHT (KGS)	DIMENSIONS (mm)					
			A	B	C	N	P	W
			Maximum Diameter	Working Height of Ball	Ball Exposure above Outer Ring	Length of Thread	Thread Size	Spring Washer Diameter

MAXIMUM DYNAMIC LOADING (kg)							
TYPE 13		TYPE 14		TYPE 15		TYPE 16	
Carbon Steel Bearings, Zinc Plated Pressings		Nylon Load Bearing, Zinc Plated Pressings		Stainless Steel Bearings and Pressings		Stainless Steel Bearings, Zinc Plated Pressings	
LOAD UP	LOAD DOWN	LOAD UP	LOAD DOWN	LOAD UP	LOAD DOWN	LOAD UP	LOAD DOWN

3004	19	0.060	32.1	24.6	4.7	40	M6	16.9
1002	25.4	0.120	39.7	32.5	6.3			20.2
2004	39.7	0.420	55.5	47.6	11.9	50	M10	Grip Range 25.4 to 32

25	10	20	10	25	10	25	10
55	25	25	10	55	25	55	25
140	60	N/A	N/A	140	60	140	60

To order, specify REF N°, TYPE and SPRING WASHER DIAMETER, i.e. 3004-13-16.9.

DIMENSIONS (mm)										
A	B	C	D	E	F	N	O	P	R	T
Maximum Diameter	Working Height of Ball	Ball Exposure above Outer Ring	Body Diameter	Distance Under Flange to Base	Flange Thickness	Length of Thread	Fixing Hole Diameter	Thread Size	Body Depth	Table Top Thickness

3007	19	0.160	61	10	3.2	14.5	3.2	30	M8	25	1
1001	25.4	0.260	73	14.2	6.3	18	3				50
1021	31.7	0.360	73.7	16.2	8	22.3	4.2	46.5	M10		1 to 27

25	10	20	10	25	10	25	10
55	25	25	10	55	25	55	25
125	55	25	10	125	55	125	55

DIMENSIONS (mm)							
A	B	C	D	E	O	S	T
Maximum Diameter	Working Height of Ball	Ball Exposure above Outer Ring	Body Diameter	Distance Under Flange to Base	Fixing Hole Diameter	Base to Top of Body	Table Top Thickness

1004	25.4	0.140	45.2	18.4	7.9	34.9	12.7	36	-	3.2
1007	25.4					35.8	11.9	To suit	-	-
1500	25.4	0.160	39.5	35.8	6.1	-	-	To suit	22.8	-

55	25	25	10	55	25	55	25
55	25	25	10	55	25	55	25
100	50	25	10	100	50	100	50

To order, specify REF N° and TYPE, i.e. 3007-13.

General Tolerance unless stated ±0.3mm

BASE FIXING UNITS

3005

Features: Heavy duty fixing. High profile. Drill hole fixing.
Optional extras: Dirt exit hole.

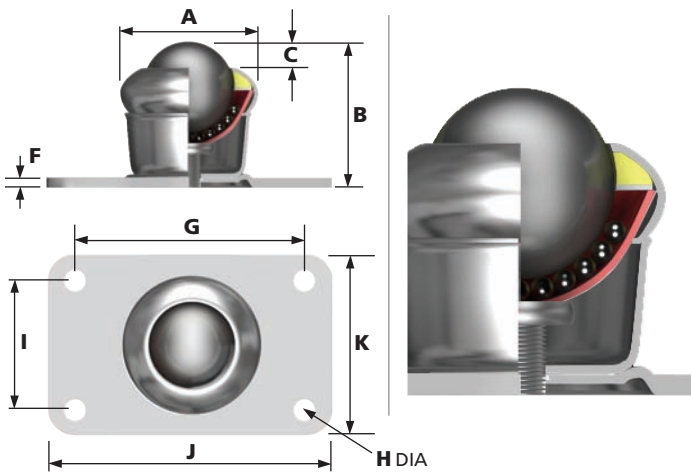

1005

Features: Heavy duty fixing. High profile. Drill hole fixing.
Optional extras: Dirt exit hole.

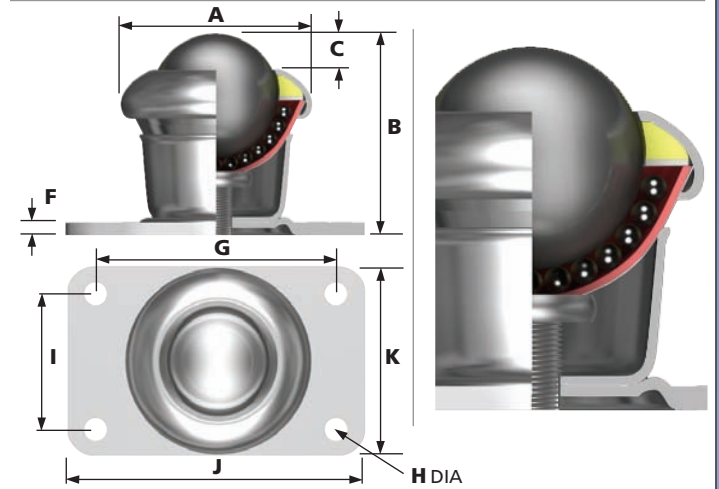

1020

Features: Heavy duty fixing. High load capacity. High profile. Drill hole fixing.
Optional extras: Dirt exit hole.

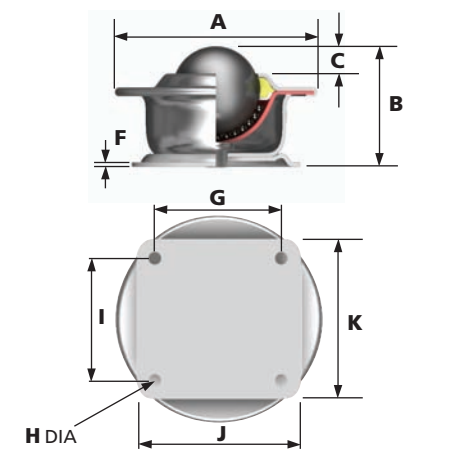

2003

Features: Heavy duty fixing. High load capacity. High profile. Drill hole fixing.
Optional extras: Dirt exit hole.

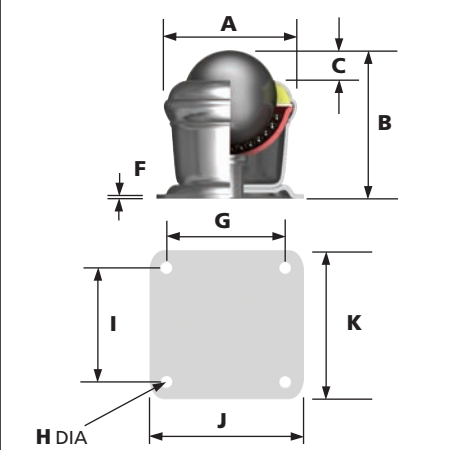

4002

Features: Heavy duty fixing. High load capacity. High profile. Dirt exit hole standard. Drill hole fixing. Can be dismantled for cleaning.
Optional extras: Grease points can be fitted.

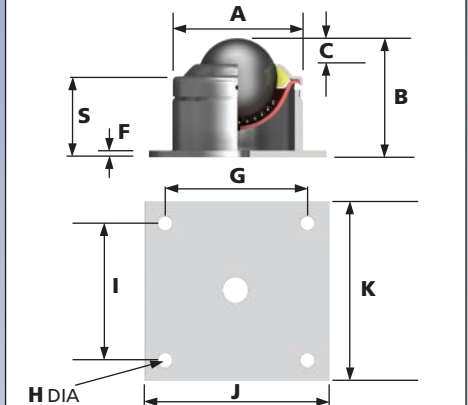

1006

Features: High load capacity. High profile. Dirt exit hole standard. Drill hole fixing. The 1041 and 1050 ball units are similar in design to the 1006 ball unit.

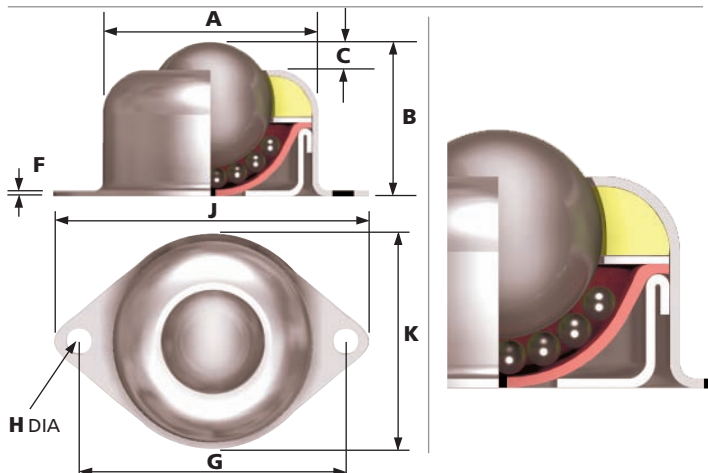

1503

Features: High load capacity. High profile. Dirt exit hole standard. Drill hole fixing. Plastic knife edge seal on main ball.

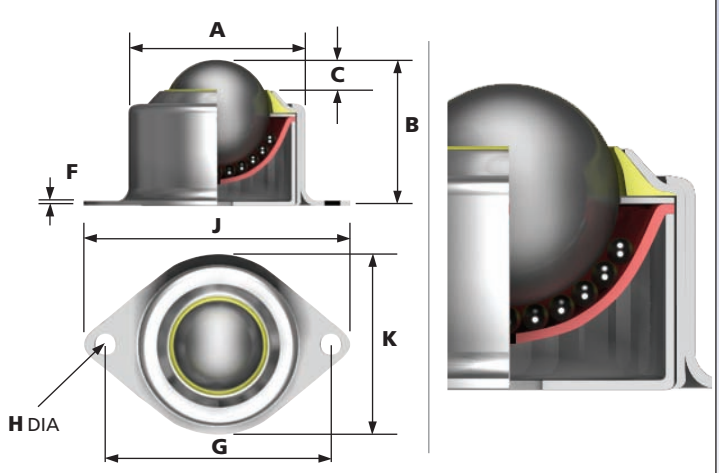

REF No.	BALL SIZE (mm)	FIXING HOLES No. of holes	WEIGHT (KGS)	DIMENSIONS (mm)										
				A	B	C	F	G	H	I	J	K	S	

MAXIMUM DYNAMIC LOADING (kg)							
TYPE 13		TYPE 14		TYPE 15		TYPE 16	
Carbon Steel Bearings, Zinc Plated Pressings		Nylon Load Bearing, Zinc Plated Pressings		Stainless Steel Bearings and Pressings		Stainless Steel Bearings, Zinc Plated Pressings	
LOAD UP	LOAD DOWN	LOAD UP	LOAD DOWN	LOAD UP	LOAD DOWN	LOAD UP	LOAD DOWN

3005	19	4	0.100	32.1	32.5	4.7	2.0	49.2 ±0.2	6.3	25.4 ±0.2	65	38	-
1005	25.4	4	0.160	39.7	41.3	6.3	2.0	49.2 ±0.2	6.3	25.4 ±0.2	65	38	-

25	10	20	10	25	10	25	10
55	25	25	10	55	25	55	25

1020	31.7	4	0.380	73	44.4	8	2.0	47.6 ±0.2	4.8	47.6 ±0.2	58.7	58.7	-
2003	39.7	4	0.480	55.5	57	11.9	2.0	47.6 ±0.2	4.8	47.6 ±0.2	58.7	58.7	-
4002	50.8	4	2.100	89	76	14.3	6.3	89 ±0.2	13.5	89 ±0.2	127	127	54

125	55	25	10	125	55	125	55
140	60	N/A	N/A	140	60	140	60
340	100	N/A	N/A	250	100	340	100

1041	15.8	2	0.042	27.5	20.0	4.0	0.9	40.0 ±0.2	5.2	-	50.0	35.0	-
1006	25.4	2	0.160	44.5	30.5	6.3	1.0	60.3 ±0.2	5.0	-	69.0	51.0	-
1050	25.4	2	0.145	42.0	31.0	7.5	1.0	56.0 ±0.2	5.5	-	69.0	51.0	-
1503	25.4	2	0.200	42	35.8	6.1	1.75	58.7 ±0.2	5.0	-	69.0	51.0	-

20	10	10	5	20	10	20	10
55	25	25	10	55	25	55	25
30	10	20	10	30	10	30	10
100	50	25	10	100	50	100	50

To order, specify REF N° and TYPE, i.e. 3005-13.

General Tolerance unless stated ±0.3mm

MINI BALL TRANSFER UNITS

REF No	Ball Size (mm)	Weight (Kg)	A	B	C	L	N	P	Dynamic Load Up Rating (Kg)
11MI-05-13	4.8	0.01	13	9	1	24	15	M6	10
11MI-05-15		0.003	8	6		8.5	2.5	M2	5
11MI-05-17									
11MI-06-13	6.4	0.02	17	11	2	26	15	M6	20
11MI-06-15		0.008	13	10.5		16.5	6	M3	10
11MI-06-17									
11MI-08-13	7.9	0.03	18	14	2	32	18	M8	30
11MI-08-15		0.011	15	12.5		20.5	8	M4	15
11MI-08-17									
11MI-10-13	9.6	0.06	23	20	2	40	20	M8	40
11MI-10-15									
11MI-13-13	12.7	0.1	28	25	3.5	48	23	M8	50
11MI-13-15									
11MI-16-13	15.8	0.05	24	20.5	4	32.5	12	M6	70
11MI-16-15									

Applications

- Measuring Equipment
- Lightweight Coilholder
- Guides for small linear motion (eg photo copier slides)
- Transfer of material in clean rooms
- Miniature mechanisms
- All thread sizes for dimension "P" are metric coarse

Carbon Steel type 13 mini ball transfer units are assembled with a small amount of oil to protect the carbon steel balls from oxidation.

Type 13 & 15

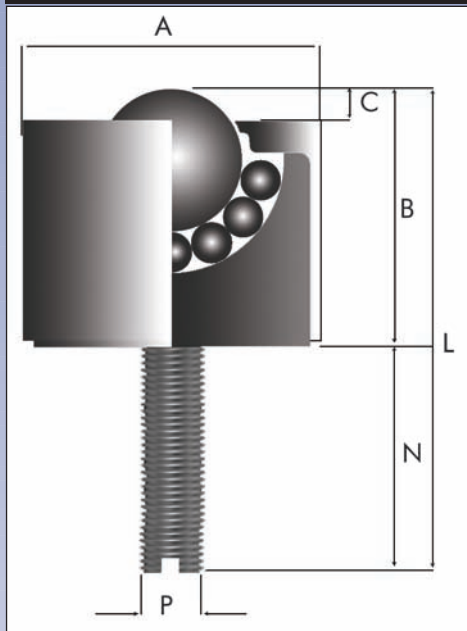

Type 17

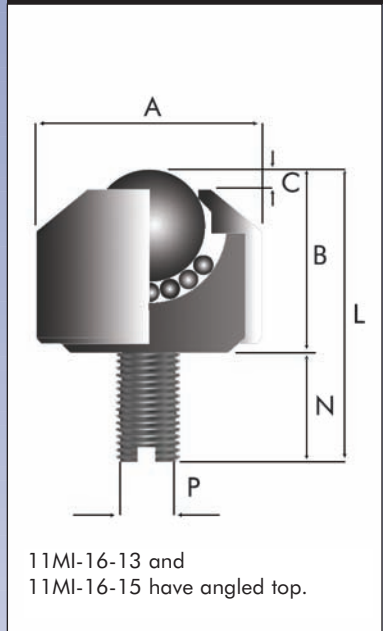

REF No	Balls	Housing
11MI-05-17 11MI-06-17 11MI-08-17	Stainless Steel Load Ball Stainless Steel Small Balls	Aluminium Outer Cover Stainless Steel Screw Thread
11MI-05-13 11MI-06-13	Carbon Steel Load Ball Stainless Steel Small Balls	Carbon Steel Outer Cover Stainless Steel Screw Thread
11MI-05-15 11MI-06-15	Stainless Steel Load Ball Stainless Steel Small Balls	Stainless Steel Outer Cover and Stainless Steel Screw Thread
11MI-08-13 11MI-10-13 11MI-13-13 11MI-16-13	Carbon Steel Load Ball Chrome Steel Small Balls	Carbon Steel Outer Cover Stainless Steel Screw Thread
11MI-08-15 11MI-10-15 11MI-13-15 11MI-16-15	Stainless Steel Load Ball Stainless Steel Small Balls	Stainless Steel Outer Cover and Stainless Steel Screw Thread

BALL TRANSFER STANDS

Allow the movement of heavy materials and large fabrications. Typical applications include the handling of plate or sheet-steel for guillotine or press brake machines.

Two types of stand are available, both made from heavy duty mild steel tube.

Overall height can vary to suit the application and can be adjusted to $\pm 38\text{mm}$.

Stands need to be positioned at not less than 60cm centres to enable an operator to pass in-between them and to move close to machinery in safety.

NOTE - posts should be fitted where there is the possibility of loads rolling off.

Minimum load dimension should not be less than the pitch of 4 stands.

Detach posts are available as an option.

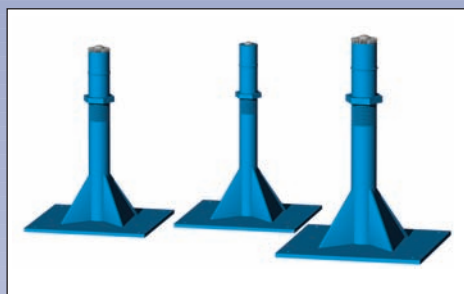

HANGER BOLTS

Ideal for the easy movement of large wall panels or sliding doors.

Ball units (ref N° 515-0, see pages 16 & 17) are secured into a circular plate with a central bolt, ideal for overhead suspension using most types of existing track. Multi-directional, they will negotiate tight curves and even right-angles with ease.



Hanger bolts can be supplied complete or self-assembly and can be produced to suit any specific application.

BALL TRANSFER STANDS

1 1/4" (32mm) size:

2 3/8" (60mm) outside diameter x 2" (50mm) inside diameter. Thread 1 1/2" B.S.P. Available in any height, 680mm is typical. Adjustment $\pm 38\text{mm}$. Capacity 250Kg.

2" (50mm) size:

3" (76mm) outside diameter x 2 1/2" (64mm) inside diameter. Thread 2 1/2" B.S.P. Available in any height, 680mm is typical. Adjustment $\pm 38\text{mm}$. Capacity 340Kg.

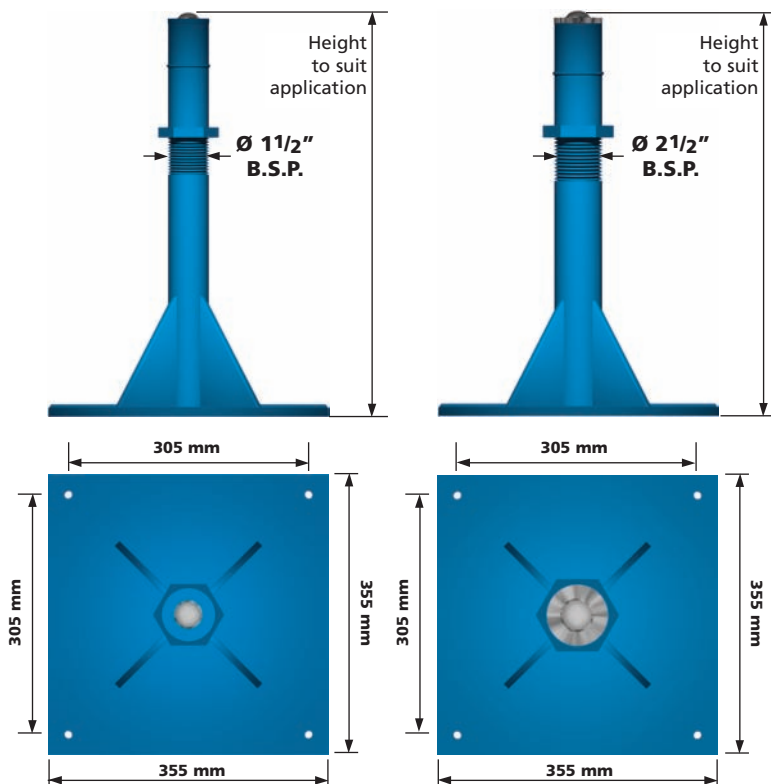

HANGER BOLTS

Standard hangerbolt: M16 x 85mm thread length with two spanner flats for easy attachment and vertical adjustment. Finish, zinc plated or stainless steel. Standard ball units: Six 515-0-13 at 60Kg load capacity with retaining clip.

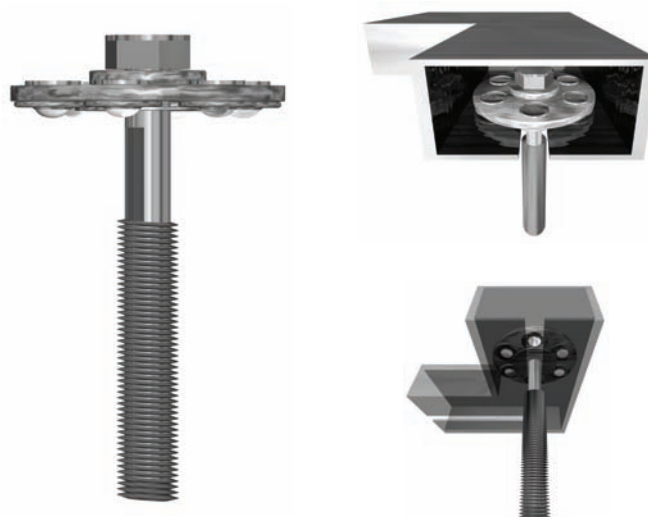

GLIDE-ALWAYSSE UNITS & FIXING SOCKETS

This is a simple and inexpensive range of ball transfer units which have a large ball exposure. They are ideal for lighter duties and where there is a cost consideration.

All units are fitted with a seal which simply and effectively removes debris by an internal plastic scraper.

The direction of rotation slightly moves the ball against the seal providing a highly effective cleaning action.

For normal applications steel bearings with zinc plated pressings and components are recommended. However, when used as a castor or in wet conditions stainless steel (Type 15) is recommended.

1700 PLUG FIXING

Features: Plain body, dirt exit hole standard.

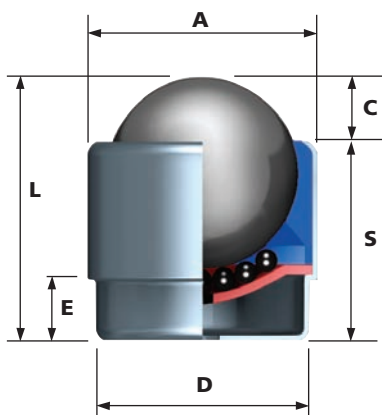

1701 BOLT FIXING

Features: Drill hole nut and bolt fixing. Maximum tightening torque is 15Nm.

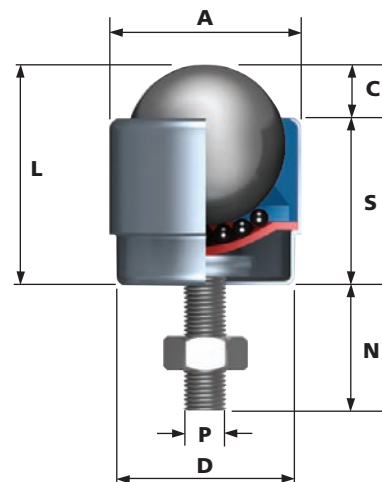

1702 FLANGE FIXING

Features: Low profile flange fixing, dirt exit hole standard.

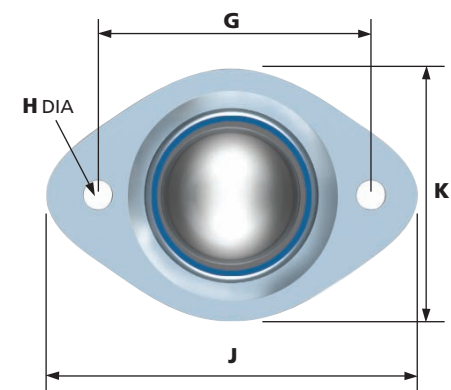
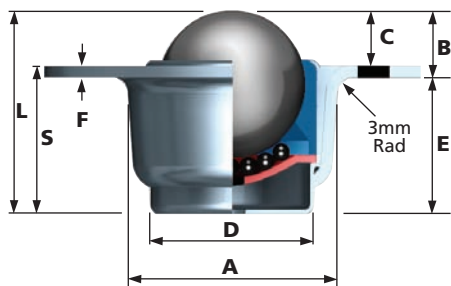

1703 PLATE FIXING

Features: High profile base plate fixing. Drill hole fixing. Dirt exit hole standard.

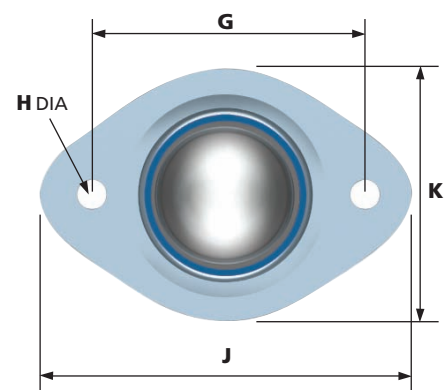
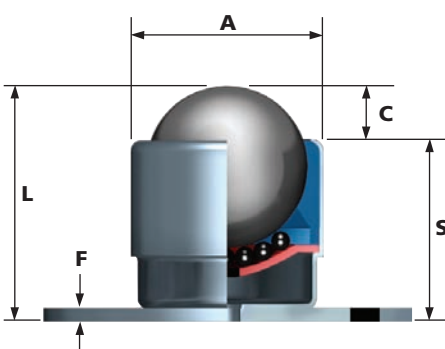

1709 GRIP NECK FIXING

Features: Plastic or steel socket fixing.

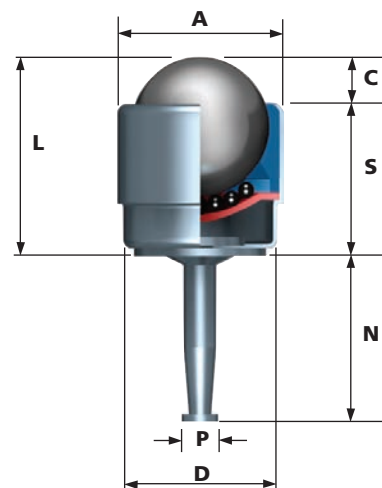

REF No.	FIXING	BALL SIZE (mm)	WEIGHT (kg)	DIMENSIONS (mm)																MAXIMUM DYNAMIC LOADING (kg)			
				A	B	C	D	E	F	G	H	J	K	L	N	P	S	TYPE 13	TYPE 14	TYPE 15	TYPE 16		

1700	PLUG	25.4	0.10	30.5	-	26.6	7.8	-	-	-	-	-	33.5	-	-	24.7
1701	BOLT			-	-		-	-	-	-	-	18 23 28		M8		
1702	FLANGE		0.12	34.5	12.4	8.8	21.1	2	48 ±0.2	5.25	64	44	35.7	-	-	23.1
1703	PLATE			-	-		2	-	-	-	-	-		26.9		
1709	GRIP NECK			30.5	-		26.6	-	-	-	-	-		34.7	34.7	7.7

50	20	50	50
----	----	----	----

To order, specify REF N° and TYPE, i.e. 1700-13.

General Tolerance unless stated ±0.3mm

FIXING SOCKETS FOR GLIDE-ALWAYSSE 1704 & 1709

REF No	FOR GLIDE-ALWAYSSE UNIT	TYPE	DESCRIPTION
--------	-------------------------	------	-------------

1705	1709	GRIP NECK	 <p>TOOTHED STEEL SOCKET WITH 19mm HEAD DIAMETER For 9.5mm x 35mm drilled hole.</p> <p>APPLICATION: WOOD</p>
1707	1709	ROUND PLASTIC, SPLINED	 <p>ROUND, PLASTIC, SPLINED SOCKET Two sizes available i.e: O/D tube 15.8mm x 1.2mm wall and O/D tube 19.0mm x either 1.2 upto 1.6 wall thickness.</p> <p>APPLICATION: ROUND SECTION TUBE</p>
1708	1709	SQUARE PLASTIC, SPLINED	 <p>SQUARE, PLASTIC, SPLINED SOCKET Two sizes available i.e: 19mm outside A/F square tube x 1.2mm upto 1.6mm wall and 25.4mm outside A/F square tube x 1.2mm upto 1.6mm wall thickness.</p> <p>APPLICATION: SQUARE SECTION TUBE</p>

To order, specify REF N°, i.e. 1705.

EURO UNITS

Always Euro Units have a main bearing cup of special toughened steel with a dirt exit hole and a woollen felt seal.

Min. -30°C to max. +70°C continuous, or +100°C intermittent. Special seals may need to be fitted to suit extreme conditions. In clean conditions and without seals +150°C to +200°C are possible, using Type 15 units at reduced loads.

MATERIAL SPEC:

Stainless Steel Pressings AISI 304
 Stainless Steel Balls AISI 420
 Nylon Balls NYLON 66

EURO 0

Features: Various fixing clips available, dimensionally compatible with the 800 series, see pages 18 & 19.

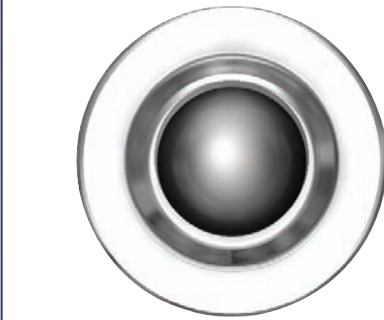
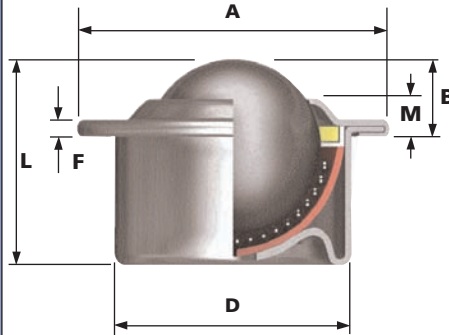

EURO 1

Features: Pop rivet or screw fixing.

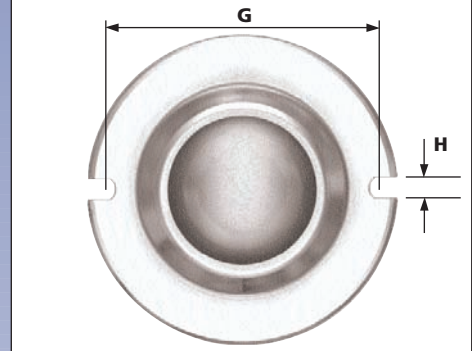
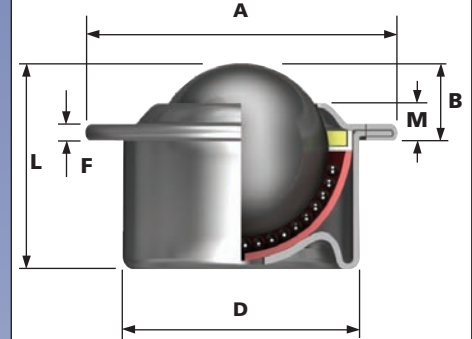

EURO 2

Features: Easy fitting with a 3 prong built-in clip from top face of ball table, compact and low profile, dimensionally identical to other Euro Unit ball units

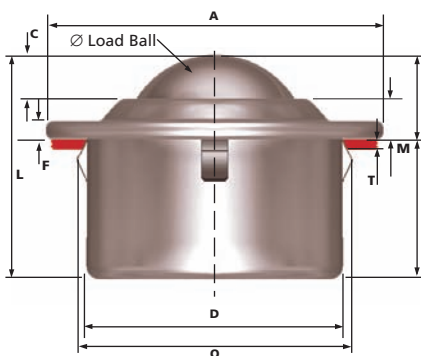

EURO 4

Features: Various fixing clips available, coned outer ring. Dimensionally compatible with the 800 series, see pages 18 & 19.

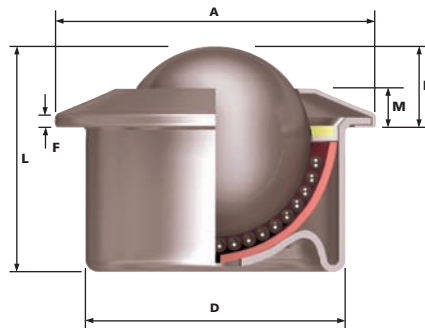

EURO 6

Features: Various fixing clips available. Reinforced coned outer ring and support cup for improved protection against shock loading. Dimensionally compatible with the 800 series. Woollen felt seals are standard except for the 515-6 ball unit.

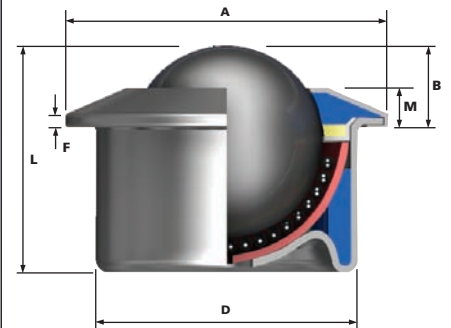

REF No.	BALL SIZE (mm)	DIMENSIONS (mm)							
		A	B	D	F	G	H	M	L
		Maximum Diameter	Working Height of Ball	Body Diameter	Flange Thickness	P.C.D. or Centres of Fixing Slots	Hole Diameter of Fixing Slots	Under Flange to Top of Outer Ring	Overall Height

515-0	15.8	31	9.5 ±0.2	24 ±0.065	2.8	-	-	6.3	21
515-1						29 ±0.2	3.5		
515-4						-	-		
515-6						-	-		

522-0	22.2	45	9.8 ±0.2	36 ±0.08	2.8	-	-	5.5	30
522-1						42 ±0.2	3.5		
522-4						-	-		
522-6						-	-		

530-0	30	55	13.8 ±0.3	45 ±0.08	4	-	-	8.3	37
530-1						51 ±0.2	3.5		
530-4						-	-		
530-6						-	-	8	

545-0	44.5	75	19 ±0.4	62 ±0.095	4	-	-	10	53.5
545-1						69 ±0.2	4.3		
545-4						-	-		
545-6						-	-		

MAXIMUM DYNAMIC LOADING (kg)							
TYPE 13		TYPE 14		TYPE 15		TYPE 16	
Carbon Steel Bearings, Zinc Plated Pressings		Nylon Load Bearing, Zinc Plated Pressings		Stainless Steel Bearings and Pressings		Stainless Steel Bearings, Zinc Plated Pressings	
WEIGHT (KGS)	CAPACITY (kg)	WEIGHT (KGS)	CAPACITY (kg)	WEIGHT (KGS)	CAPACITY (kg)	WEIGHT (KGS)	CAPACITY (kg)

0.043	60	0.028	10	0.043	38	0.043	60
0.043	60	0.028	10	0.043	38	0.043	60
0.043	60	0.028	10	0.043	38	0.043	60
0.054	60	0.039	10	0.054	38	0.054	60

0.132	160	0.096	20	0.132	100	0.132	160
0.132	160	0.096	20	0.132	100	0.132	160
0.132	160	0.096	20	0.132	100	0.132	160
0.165	160	0.130	20	0.165	100	0.165	160

0.278	300	0.182	25	0.278	200	0.278	300
0.278	300	0.182	25	0.278	200	0.278	300
0.278	300	0.182	25	0.278	200	0.278	300
0.335	300	0.238	25	0.335	200	0.335	300

0.725	610	-	-	0.725	250	0.725	610
0.725	610	-	-	0.725	250	0.725	610
0.725	610	-	-	0.725	250	0.725	610
0.887	610	-	-	0.887	250	0.887	610

REF No.	LOAD BALL SIZE (mm)	DIMENSIONS (mm)									
		A	B	C	D	E	F	M	L	O	T
		Maximum Diameter (mm)	Working Height of Ball (mm)	Ball Exposure (mm)	Body Diameter (mm)	Distance from under Flange to Base (mm)	Flange Thickness (mm)	Under Flange to top of Outer Ring (mm)	Overall Length (mm)	Seating Hole Diameter (mm)	Table Top Material Thickness (mm)

515-2	15.8	31	9.5 ±0.2	3.2	24 ±0.1	11.5	2.8	6.3	21	25.0 25.5	2
522-2	22.2	45	9.8 ±0.2	4.3	36 ±0.1	20.2	2.8	5.5	30	37.0 37.5	3
530-2	30	55	13.8 ±0.2	5.5	45 ±0.1	23.2	4	8.3	37	46.0 46.5	6
545-2	44.5	75	19 ±0.2	9	62 ±0.1	34.5	4	10	53.5	63.0 63.5	7

MAXIMUM DYNAMIC LOADING (kg)							
TYPE 13		TYPE 14		TYPE 15		TYPE 16	
Carbon Steel Bearings, Zinc Plated Pressings		Nylon Load Bearing, Zinc Plated Pressings		Stainless Steel Bearings and Pressings		Stainless Steel Bearings, Zinc Plated Pressings	
WEIGHT (KGS)	CAPACITY (kg)	WEIGHT (KGS)	CAPACITY (kg)	WEIGHT (KGS)	CAPACITY (kg)	WEIGHT (KGS)	CAPACITY (kg)

0.043	60	0.028	10	0.043	38	0.043	60
0.132	160	0.096	20	0.132	100	0.132	160
0.278	300	0.182	25	0.278	200	0.278	300
0.725	610	-	-	0.725	250	0.725	610

To order, specify REF N° and TYPE, i.e 515-0-13.

For load down use as a castor, reduce dynamic load rating by 50%.

CL14 FIXING CLIPS (Please see pages 30 and 31 for CL14 fixing clip dimensions)

REF No.	SUITABLE FOR UNITS
---------	--------------------

CL14-515	515-0, 515-4, 515-6
CL14-522	522-0, 522-4, 522-6
CL14-530	530-0, 530-4, 530-6
CL14-545	545-0, 545-4, 545-6

To order, specify REF N°, i.e CL14-515.

FIXING HOLE SIZES (mm)	
------------------------	--

24	+1.0 +1.5
36	+1.0 +1.5
45	+1.0 +1.5
62	+1.0 +1.5

General Tolerance unless stated ±0.3mm

HEAVY-DUTY UNITS, SERIES 800

HEAVY DUTY 800

Features: High load capacity, low profile, robust construction.

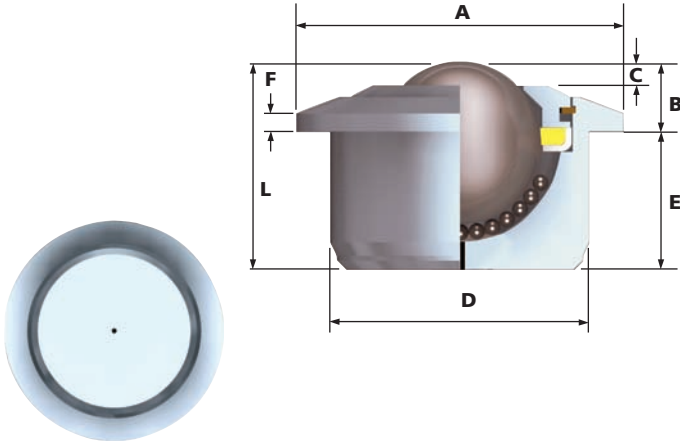

HEAVY DUTY 805

Features: High load capacity, low profile, robust construction. Multi-hole drain plug provides an extra 600% debris hole area to assist in cleaning.

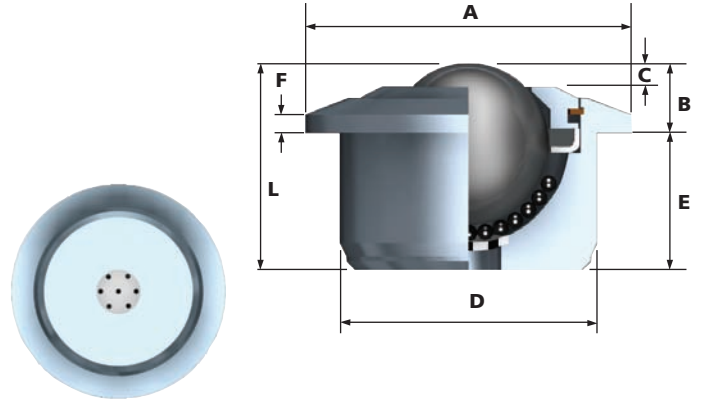

HEAVY DUTY 806

Features: High load capacity, low profile, can be disassembled. Slotted dirt exit hole allows large debris particles to pass through.

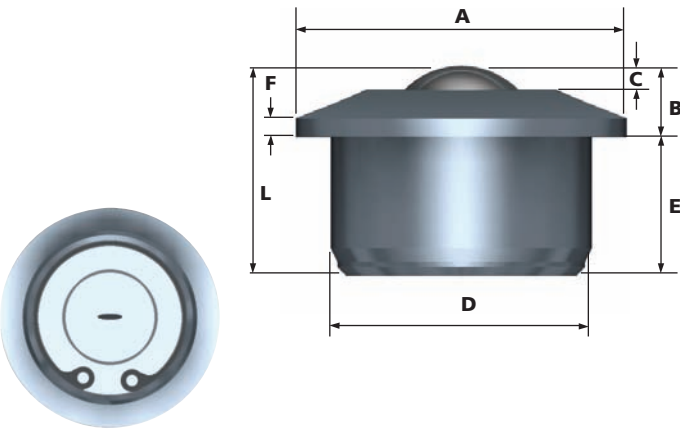

HEAVY DUTY 807

Features: High load capacity, low profile. Slotted dirt exit hole allows large debris particles to pass through.

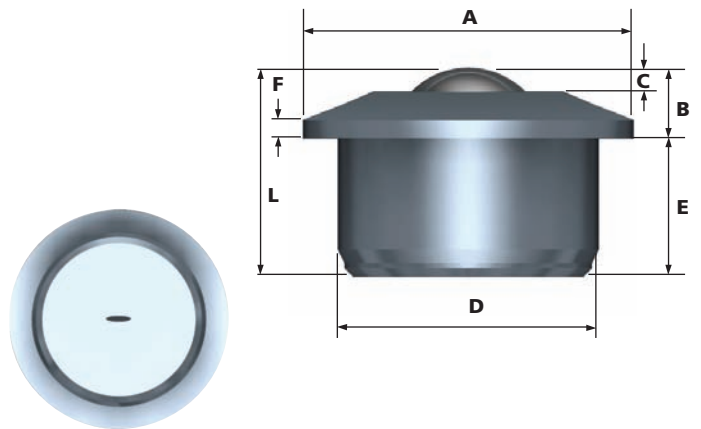

HEAVY DUTY 810

Features: High load capacity, low profile, coned outer ring.

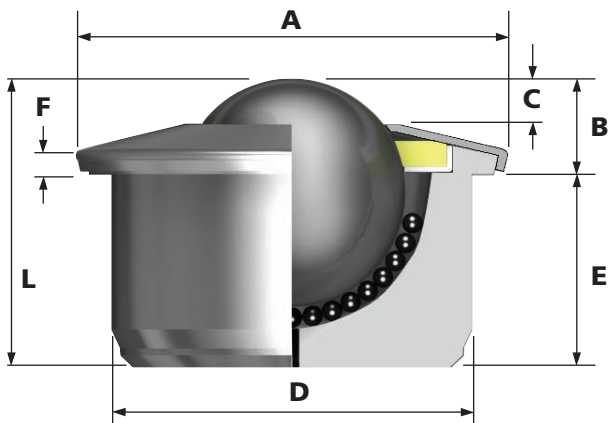

HEAVY DUTY 820

Features: High load capacity, solid body and robust outer ring for greater durability. Can be dismantled for cleaning.

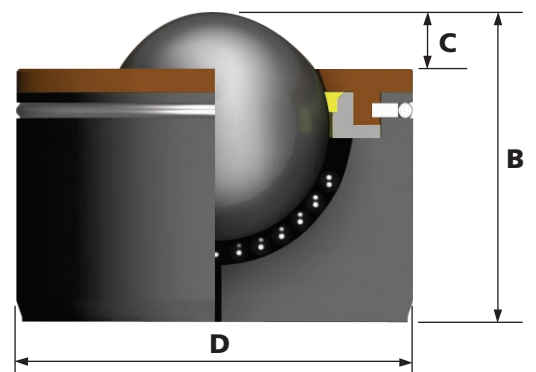

Always Series 800 are solid body steel ball units.

They incorporate a seal and dirt exit hole for maximum efficiency and smooth running.

Our CNC production plant can produce special designs to individual customers requirements.

Easy fixing clips are available, ref no. CL14, for quick and effective fixing, see pages 30 and 31. When used the working height of the ball unit dimension 'B' is increased by 0.3mm.

800 Series Type 15, Stainless Steel



In general ball unit sizes from Ø15.8mm to Ø44.5mm will have unhardened components typically 304 stainless steel.

Ball units with Ø57.1mm, Ø76.2mm and Ø88.9mm balls have hardened bodies.

805 Heavy Duty Ball Units

Similar to 800 series units, the 805 ball units incorporate a stainless steel multi-hole drain plug for improved cleaning and debris removal, stainless bearings for corrosion resistance, and no seal for easy cleaning and reduced friction.

The 800, 805, 806, 807 and 810 range of ball units are dimensionally compatible with our Euro Unit range of ball transfer units, see pages 16 and 17.

REF No.	BALL SIZE (mm)	WEIGHT (KGS)	DIMENSIONS (mm)							MAXIMUM DYNAMIC LOADING (kg)		
			A Maximum Diameter	B Working Height of Ball	C Ball Exposure above Outer Ring	D Body Diameter	E Distance Under Flange to Base	F Flange Thickness	L Overall Height	TYPE 13 Carbon Steel Bearings, Zinc Plated Pressings  LOAD UP*	TYPE 15 Stainless Steel Bearings and Pressings  LOAD UP*	TYPE 16 Stainless Steel Bearings, Zinc Plated Pressings  LOAD UP*
800-22	22.2	0.18	45	9.8 ±0.2	3.8	36 ±0.08	20.7	3.0	30.5	180	120	180
800-30	30	0.38	55	13.8 ±0.2	5.5	45 ±0.08	23	3.4	36.8	350	200	350
800-45	44.5	1.10	75	19	9	62 ±0.1	34.5	3.8	53.5	600	300	600
800-60	57.1	3.80	117	29.5	16.5	100 ±0.1	48	5.0	77.5	1500	1000	1000
805-30	30	0.38	55	13.8 ±0.2	5.5	45 ±0.08	23	3.4	36.8	350	200	350
805-45	44.5	1.10	75	19	9	62 ±0.1	34.5	3.8	53.5	600	300	600
806-30	30	0.35	55	13.8 ±0.2	5.5	45 ±0.08	23	3.4	36.8	350	200	350
807-30	30	0.36	55	13.8 ±0.2	5.5	45 ±0.08	23	3.4	36.8	350	200	350
810-15	15.8	0.06	31	9.5 ±0.2	4	24 ±0.06	11.5	3.8	21	56	43	56
810-22	22.2	0.20	45	9.8 ±0.2	3.5	36 ±0.08	20.7	4.0	30.5	180	120	180
810-30	30	0.37	55	13.8 ±0.2	5.5	45 ±0.08	23	5.0	36.8	350	200	350
810-45	44.5	0.99	75	19	9	62 ±0.1	34.5	4.5	53.5	600	300	600
820-60	57.1	3.5	-	77.5	16.5	100 ±0.1	-	-	-	1500	-	1000
820-76	76.2	8.6	-	103	23	130 ±0.1	-	-	-	3000	-	2500
820-90	88.9	11.0	-	115	25	145 ±0.1	-	-	-	4000	-	3500

100 Kgs

To order, specify REF N° and TYPE, i.e. 800-22-13.

General Tolerance unless stated ±0.3mm

*Please consult us when mounting in inverted position as a castor, load down.

HI-TECH, DOUBLE SEAL, UNITS

DOUBLE SEAL

This is the first ball transfer design that incorporates double sealing for excluding debris from the bearings.

The top cover seal removes larger particles and the inner knife edge scraper seal skims liquid, paste, fine dust, etc. off the large ball and expels it through side vents.

A dirt exit hole can also be incorporated.

RUST RESISTANT UNITS (Type 15 only)

All parts are of non-rusting material, impervious to the most severe industrial environment and have high impact resistance.

The main bearing track is hardened and has been load and life tested. The ball unit runs equally well inverted or at an angle.

MATERIALS

Steel (Type 13) or stainless (Type 15) load components and bearings.

Hi-Tech Units have the same rated load capacities as the Ø25.4mm Hevi-Load units (see pages 22 & 23). The Hi-tech units have glass re-inforced nylon bodies so their weight is less than half that of the Ø25.4mm Hevi-Load units.

Stainless steel bearings with steel load components (Type 16) are available on request.

CHEMICAL RESISTANCE

High resistance to organic solvents, petrol and oil.

Seek our advice if in doubt.

TEMPERATURE

-30°C upto +100°C.

6025-0

Features: High load Capacity. Dimensionally compatible with Hevi-Load 7121.

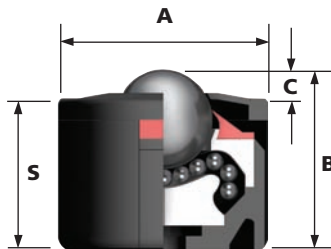

6025-1

Features: Bolt fixing high load capacity. If used for height adjustment the locknut must remain secured to the body. Maximum tightening torque is 15Nm.

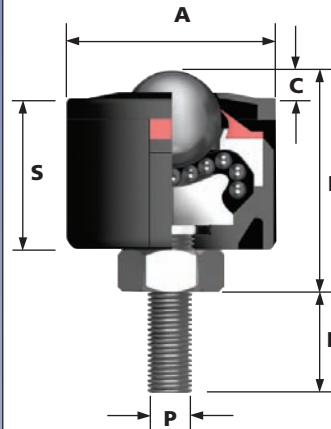

6025-2

Features: Top flange high load capacity. Dimensionally compatible with Hevi-load 7125.

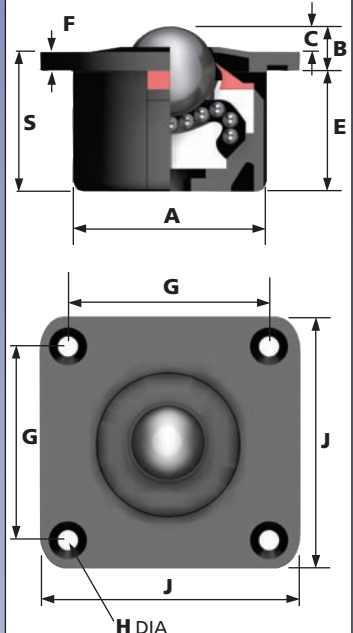

6025-3

Features: High load capacity. Ball height compatible with Hevi-load 7123.

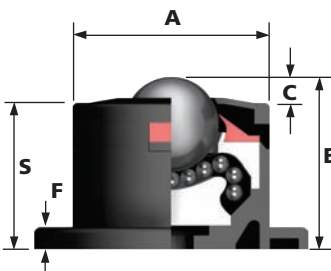

6025-4

Features: High load capacity. Coned flange for smoother on-off transfer.

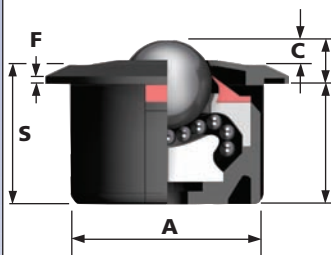

6025-5

Features: Ideal for shock loading. Stainless steel springs available on request. Compatible with Hevi-load 7136, 7139, 7137, 7135.

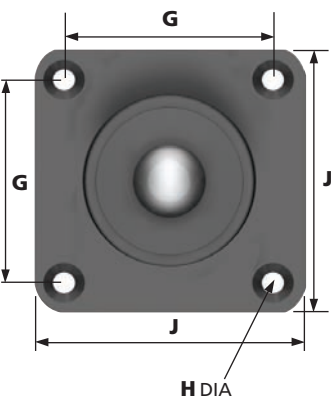
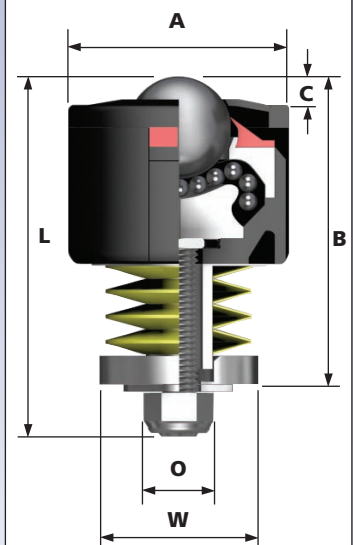

REF No.	BALL SIZE (mm)	BEARING COMPONENTS	WEIGHT (KGS)	DIMENSIONS (mm)										DYNAMIC LOAD CAPACITY (kg)	
				A	B	C	E	F	G	H	J	N	P	S	TYPE 13

TYPE 0																
6025-0-15	25.4	Stainless	0.238	50.8	45.0	6.7	-	-	-	-	-	-	-	38.3	-	240
6025-0-13		Ferrous													320	-

TYPE 1																
6025-1-15	25.4	Stainless	0.274	50.8	53	6.7	-	-	-	-	-	17.6	M10	38.3	-	240
6025-1-13		Ferrous													320	-

TYPE 2																	
6025-2-15	25.4	Stainless	0.260	50.8	13.0	6.7	32.0	6.3	58.0 ±0.2	6.7	13.2	76.0	-	-	38.3	-	240
6025-2-13		Ferrous														320	-

TYPE 3																	
6025-3-15	25.4	Stainless	0.260	50.8	45.0	6.7	-	6.3	58.0 ±0.2	6.7	13.2	76.0	-	-	38.3	-	240
6025-3-13		Ferrous														320	-

TYPE 4																
6025-4-15	25.4	Stainless	0.250	50.8	13.0	6.7	32.0	3.0	-	-	68.6	-	-	38.3	-	240
6025-4-13		Ferrous													320	-

General Tolerance unless stated ±0.3mm

DIMENSIONS (mm)					
A	B	C	L	O	W
Maximum Diameter	Working Height of Ball	Ball Exposure Above Outer Ring	Overall Length	M10 Nut Clearance Diameter	Collar Diameter

DYNAMIC SUPPORT LOAD (Kg)	LOAD FOR MAXIMUM DEFLECTION	
	(Kg)	(mm)
7	100	3.2
23	110	3.2
45	120	3.2
70	125	3.2
90	210	3.2
140	245	3.2
180	270	3.2
230	310	3.2

TYPE 5														
6025-5-15A	25.4	Stainless	0.330	50.8	61.9	6.7	77.0	20.0	38.1	7	100	3.2	-	-
6025-5-13A		Ferrous												
6025-5-15B	25.4	Stainless	0.330	50.8	61.5	6.7	77.0	20.0	38.1	23	110	3.2	-	-
6025-5-13B		Ferrous												
6025-5-15C	25.4	Stainless	0.330	50.8	60.7	6.7	77.0	20.0	38.1	45	120	3.2	-	-
6025-5-13C		Ferrous												
6025-5-15D	25.4	Stainless	0.335	50.8	61.9	6.7	77.0	20.0	38.1	70	125	3.2	-	-
6025-5-13D		Ferrous												
6025-5-15E	25.4	Stainless	0.470	50.8	81.0	6.7	98.4	20.0	38.1	90	210	3.2	-	-
6025-5-13E		Ferrous												
6025-5-15F	25.4	Stainless	0.470	50.8	79.8	6.7	98.4	20.0	38.1	140	245	3.2	-	-
6025-5-13F		Ferrous												
6025-5-15G	25.4	Stainless	0.480	50.8	81.0	6.7	98.4	20.0	38.1	180	270	3.2	-	-
6025-5-13G		Ferrous												
6025-5-15H	25.4	Stainless	0.490	50.8	81.0	6.7	98.4	20.0	38.1	230	310	3.2	-	-
6025-5-13H		Ferrous												

To order, specify REF No, i.e. 6025-0-15.

General Spring Rating Tolerance unless stated ±10%

HEVI-LOAD UNITS 0,1,2 & 3

Always Hevi-Load Units are designed and manufactured to precise standards.

They offer the highest performance available in load transfer applications with load ball sizes from 12.7mm to 50.8mm diameters and a load capacity range from 35kg to 2000kg used either ball up or ball down.

Hevi-Load Units run on the re-circulating ball principal. The load ball rotates on a bed of small balls supported on a hardened steel, precision machined table.

They can work at maximum capacity in temperatures from - 30°C to +100°C.

Drain hole or grease points can be incorporated on request.

No spanner flats for 7110 and 7106 Hevi-Load Units. *Models marked with an asterisk have a bearing shell and are assembled with no felt seal.

Type 15 Units (all stainless steel) available on request. When using stainless balls, reduce Type 13 load capacity by 33.3%.

All units are machined using CNC machines from one piece of steel, therefore flanges and threads are integral.

All hevi-load units have a zinc iron black coated housing for corrosion resistance.

HEVI-LOAD 0

Features: High load capacity, robust body. The Hevi-Load 7121 is dimensionally compatible with the Hi-Tech 6025-0.

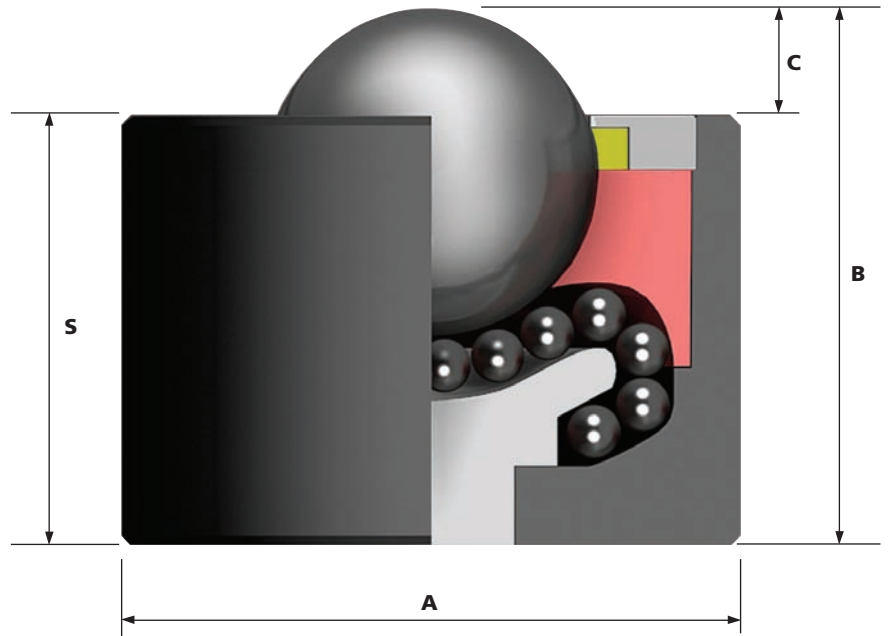

HEVI-LOAD 1

Features: High load capacity, bolt fixing. Two spanner flats for fixing and removing. Drill hole fixing. Maximum tightening torques range from 15Nm for M8 to 25Nm for M24.

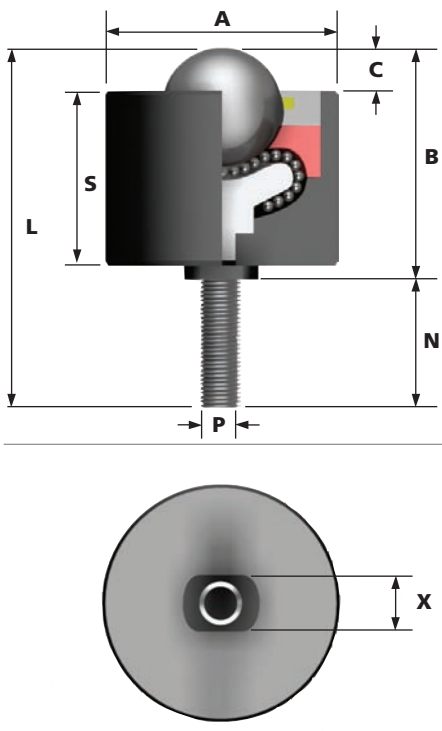

HEVI-LOAD 2

Features: High load capacity, top flange fixing. The Hevi-Load 7125 is dimensionally compatible with the Hi-Tech 6025-2.

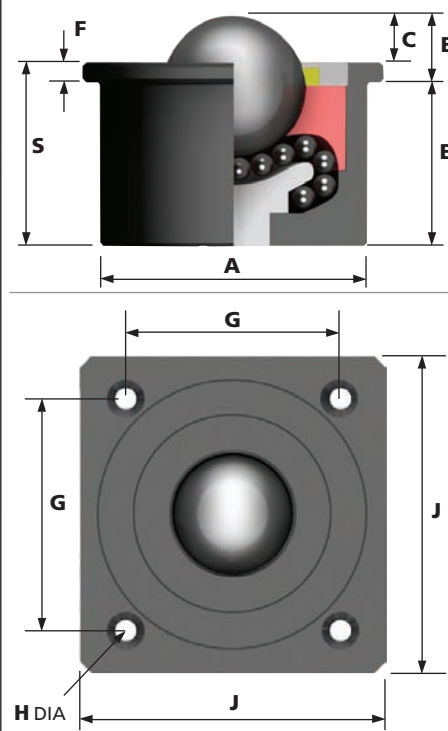

HEVI-LOAD 3

Features: High load capacity, bottom flange fixing. Drill hole fixing. The Hevi-Load 7123 is dimensionally compatible with the Hi-Tech 6025-3.

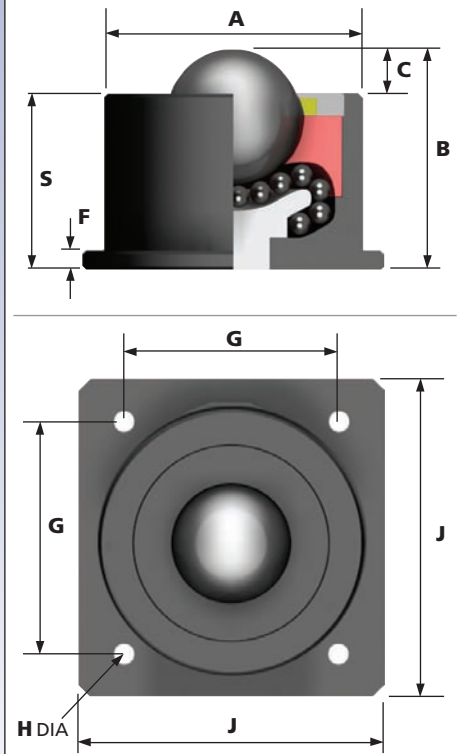

PATTERN	REF No.	BALL SIZE (mm)	WEIGHT (KGS)	DIMENSIONS (mm)								DYNAMIC LOAD CAPACITY (kg)	
				A	B	C	L	N	S	P	X	TYPE 13	TYPE 16

HEVI-LOAD 0	7101*	12.7	0.036	20.6	19.6	3.5			16.1			35	35
	7120	25.4	0.394	44.5	41.4	5.6			35.8			135	135
	7121			50.8	44.7	6.1	-	-	38.6	-	-	320	215
	7150	38.1	1.0	60.0	61.5	13			48.5			1000	670
	7170	50.8	5.02	101.6	98.4	14.3			84.1			2000	1330

HEVI-LOAD 1	7110*	12.7	0.042	20.6	19.6	3.5	35.8	16.2	16.1	5/16" UNF	-	35	35	
	7106*											M8		
	7127	25.4	0.431	44.5	48.3	5.6	72.4	24.1	35.8	1/2" UNF	19	135	135	
	7128									M12				
	7130										M12	19	320	215
	7131			0.581	50.8	51.3	6.1	77	25.7	38.6	1/2" UNF			
	7153	38.1	1.14	60.0	73.5	13	114.3	40.8	48.5	M20	30	1000	670	
	7154									3/4" UNF				
	7172	50.8	5.26	101.6	109.1	14.3	159	49.9	84.1	M24	38	2000	1330	
7173									1" UNF					

DIMENSIONS (mm)											DYNAMIC LOAD CAPACITY (kg)	
A	B	C	E	F	G	H	J	S			TYPE 13	TYPE 16
Maximum Diameter	Working Height of Ball	Ball Exposure above Outer Ring	Distance Under Flange to Base	Flange Thickness	Centres of Fixing Holes	Hole Diameter & Fixing Holes	Major Flange Size	Base to Top of Body			Carbon Steel Balls.	Stainless Steel Balls.

Hevi-Load ball units Ref. No's 7104 and 7103 have a round flange with two fixing holes.

HEVI-LOAD 2	7104*	12.7	0.082	23.8	11.2	3.5	11.2	3.2	34.8 ±0.2	2x3.6	44.5	19.1	35	35
	7124	25.4	0.463	44.5	10.3	5.6	31.3	4.7	44.5 ±0.2	4x5.6	57.2	36	135	135
	7125			50.8	13.0	6.1	32.0	6.9	57.9 ±0.2	4x7.1	76.2	38.9	320	215
	7152	38.1	1.24	60.0	25.4	13	35.8	12.4				48.2	1000	670
	7171	50.8	6.14	101.6	33.3	14.3	65.0	19.0	101.6 ±0.2	4x11	127.0	84	2000	1330

HEVI-LOAD 3	7103*	12.7	0.086	23.8	22.6	3.5	-	3.2	34.8 ±0.2	2x3.6	44.5	19.1	35	35
	7122	25.4	0.459	44.5	41.4	5.6	-	4.8	44.5 ±0.2	4x5.6	57.2	35.8	135	135
	7123			50.8	45.5	6.4	-	6.3	57.9 ±0.2	4x7.1	76.2	39.1	320	215
	7151	38.1	1.3	60.0	62.2	13	-	12.4				49.2	1000	670
	7174	50.8	5.52	101.6	98.3	14.3	-	9.6	101.6 ±0.2	4x11	127.0	84.0	2000	1330

To order, specify REF N° and TYPE, i.e. 7101-13.

General Tolerance unless stated ±0.3mm

HEVI-LOAD 5,6 • DIE LIFTERS

HEVI - LOAD 5

Features: High load capacity, greater shock loading protection. Screw fixing collar for Ø38.1mm and Ø50.8mm ball units only, for secure fixing in ball down applications.

*Ball units 7107, 7108 and 7109 incorporate the shell ball design and have no seal.

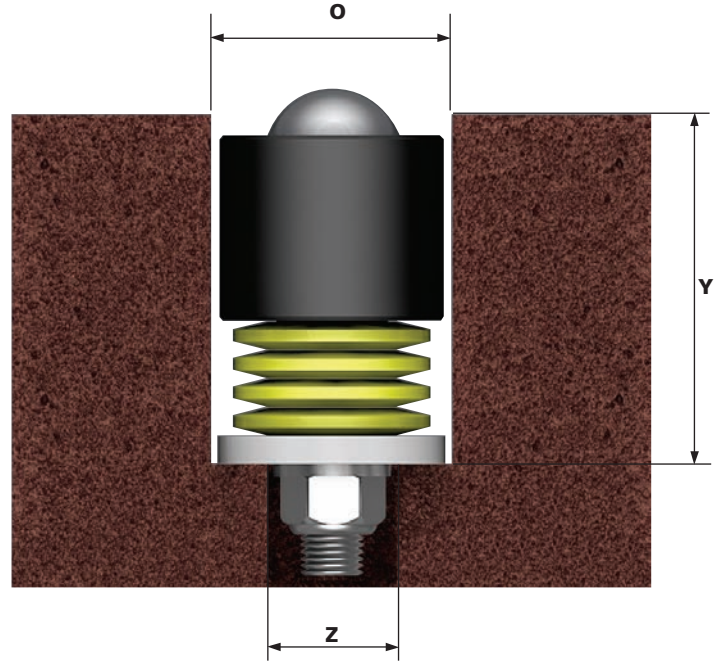
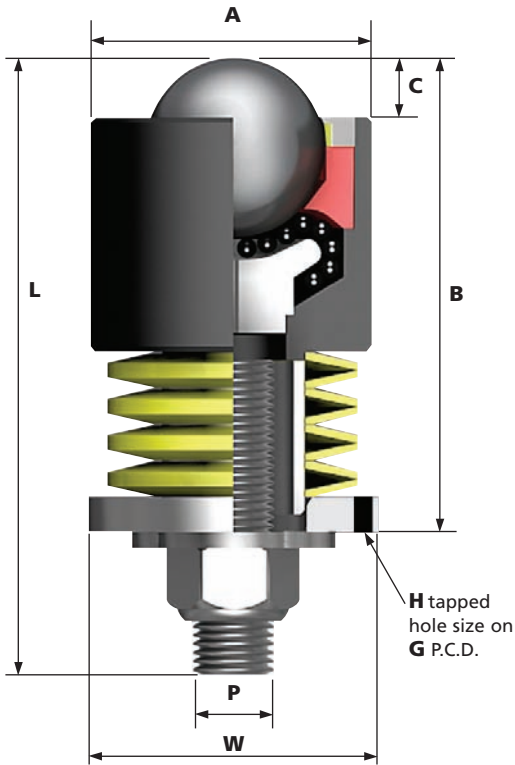

HEVI - LOAD 6

Features: Compact, interference fitting, greater shock loading protection.

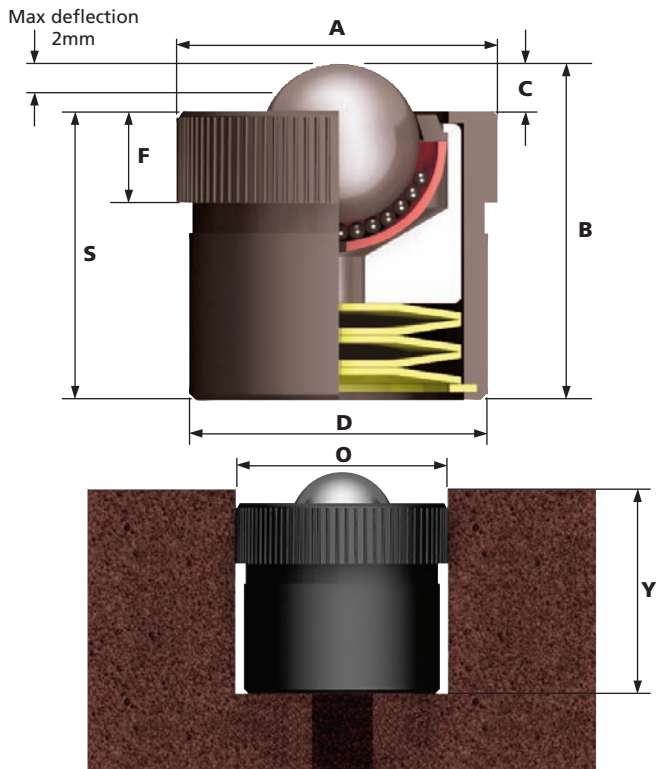

DIE LIFTERS

Features: Tolerance ring for interference fitting for ball up and ball down fitting. Greater shock loading protection.

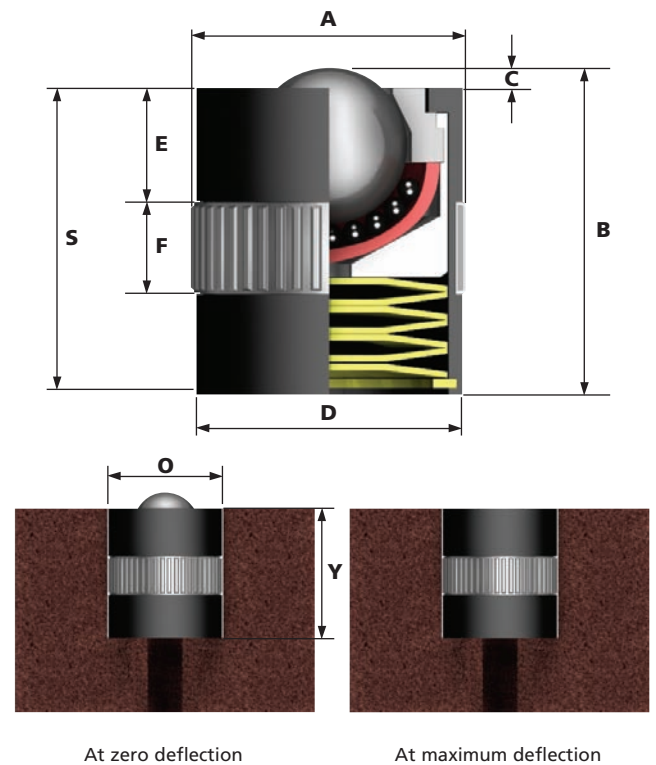

PATTERN	REF No.	BALL SIZE (mm)	WEIGHT (KGS)	DIMENSIONS (mm)									
				A	B	C	G	H	L	O	P	W	Y

DYNAMIC LOAD CAPACITY (kg)				
SUPPORT LOAD (Kg)	LOAD FOR MAXIMUM DEFLECTION (Kg)		MAXIMUM DEFLECTION (mm)	
	TYPE 13	TYPE 16	TYPE 13	TYPE 16

HEVI-LOAD 5	7107*	12.7	0.067	20.6	32.2	3.5	-	47.0	22	M8	20.6	29.8	16		
	7108*													31.8	
	7109*													32.2	
	7138	25.4	0.517	44.5	61.9	5.6	-	77.0	46	M10	38.1	77.8	22		
	7132													61.5	
	7133													60.7	
	7134													61.9	
	7135													81.0	
	7136													79.8	
	7139	38.1	0.804	50.8	81.0	6.1	-	98.4	52	M16	59.4	121.4	32		
	7137													0.813	
	7155													1.860	
	7158	50.8	9.0	101.6	179.4	14.3	76 ±0.2	4x M8	200.8	103	M24	101.6	168.3	44	
	7159														1.940
	7156														2.040
	7160														1.980
	7157														2.220
	7178														2.620
	7175	50.8	9.0	101.6	177.4	14.3	76 ±0.2	4x M8	200.8	103	M24	101.6	165.2	44	
	7176														174.6
7177	171.5														

General Spring Rating Tolerance ±10%

7	7	30	30	2
15	15	35	35	
25	25	40	40	
7	7	100	100	3.2
25	25	110	110	
45	45	120	120	
70	70	125	125	
90	90	210	210	
140	140	245	245	
180	180	270	270	5.6
230	230	310	310	
225	225	630	630	
310	185	685	380	
460	230	765	410	
565	375	830	685	
690	460	875	660	6.3
760	565	910	745	
795	335	1370	660	
1000	685	1615	955	
1235	830	1785	1030	
1560	930	1950	1520	

DIMENSIONS (mm)							
A	B	C	D	F	O	S	Y

HEVI-LOAD 6	7105	12.7	0.078	25.6	28.5	3.1	25.4	8	25.4 +0.15 +0.05	25.4	26.5
-------------	------	------	-------	------	------	-----	------	---	------------------	------	------

25	25	40	40	2
----	----	----	----	---

DIMENSIONS (mm)								
A	B	C	D	E	F	O	S	Y

DIE-LIFTERS	DL-24	12.7	0.074	24.5	30	1.5	23.9	9	10.5	24.1	28.5	28.6
	DL-30	15.8	0.127	30.5	36	1.5	29.9	12	10.5	30.1	34.5	34.6
	DL-40	25.4	0.320	40.5	48	1.5	39.8	12	10.5	40.1	46.5	46.6
	DL-50	30	0.660	50.5	60	1.5	49.9	15	12.3	50.1	58.5	58.6
	DL-70	38.1	2.000	71	80	2	70	19	19	70.2	78	78.1

General Spring Rating Tolerance ±10%

40	40	90	90	1.5
60	60	110	110	1.5
100	100	175	175	1.5
335	200	585	465	1.5
500	325	720	570	2

To order, specify REF N° and TYPE, i.e. 7107-13.

General Tolerance unless stated ±0.3mm



SPRING LOADED UNITS

Always spring loaded units are used in applications such as:-

Guillotines; Presses;
Moulding Machines; Tool Bases;
Press Brakes; Shock Loading applications.

Spring loaded ball units reduce damage caused by shock loads. They also allow for dimension changes due to temperature and self-adjust to evenly distribute loads.

1507, 1508 and 1509 Units

These units incorporate a plastic scraper seal, which keeps debris outside the ball unit.

Spring loaded ball unit sizes Ø31.7mm, Ø39.7mm and Ø50.8mm have dirt exit holes as standard. All other spring loaded ball units have felt or foam seals as standard.

Spring loaded ball units can be used as die-lifters, inverted or at an angle.

See pages 24 and 25 for details of our Hevi-Load spring loaded ball units and Die-Lifter ball units.

Completely stainless steel (Type15) spring loaded ball units also available upon request with reduced support loads and depress loads.

Spring loaded ball units with ball sizes of Ø25.4mm also available upon request with nylon load ball and stainless bearings (Type 14).

The Type 14 ball units are suitable for light load applications and when object surface protection is required.

The 1507 and 1509 ball units have 2mm thick pressed steel flanges.

Do not remove the circlip on any of the spring loaded ball units.

* Other loads available upon request.

LARGE TOP FLANGE

Features: Large top flange fixing. Low profile.

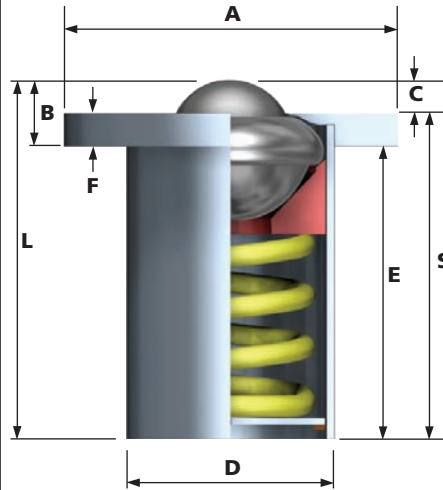

(1018 shown here)

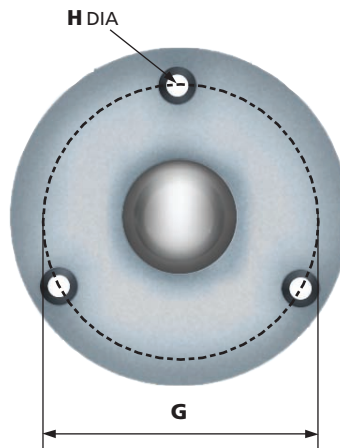

LARGE BOTTOM FLANGE

Features: Large bottom flange fixing. High profile.

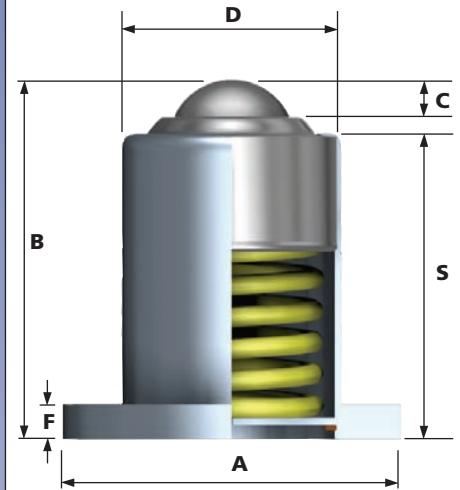

(1032 shown here)

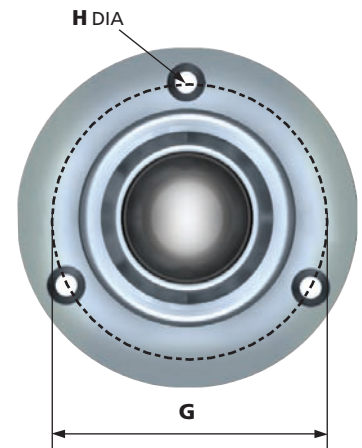

5320

Features: The 5320 ball unit is assembled with a 522-0 ball unit (see pages 16-17). The ball unit has a dirt exit hole.



Please see large top flange for dimensions.



PLAIN BODY

Features: Plain body. Low profile.

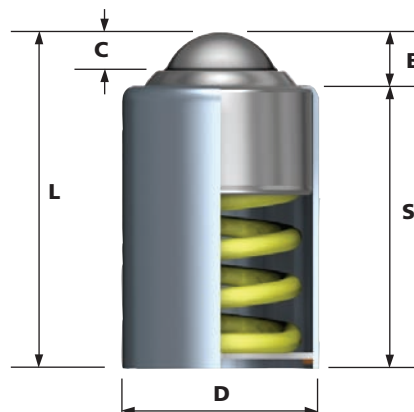

(1508 shown here)

SMALL TOP FLANGE

Features: Small flange. Low profile.

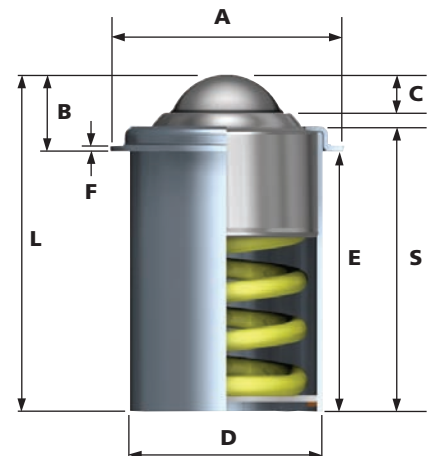

(1509 shown here)



REF No.	BALL SIZE (mm)	WEIGHT (KGS)	DIMENSIONS (mm)									
			A	B	C	D	E	F	G	H	L	S
			Maximum Diameter	Working Height of Ball	Ball Exposure above Outer Ring	Body Diameter	Distance Under Flange to Base	Flange Thickness	P.C.D. or Centres of Fixing Holes	Hole Diameter of Fixing Holes & No. of Fixing Holes	Overall Height	Base to Top of Body

SUPPORT DYNAMIC LOAD (kg)	LOAD TO FULLY DEPRESS (kg)
TYPE 13 Carbon Steel Bearings, Zinc Plated Pressings	
TYPE 16 Stainless Steel Bearings, Zinc Plated Pressings	

Confirmar

LARGE TOP FLANGE

3011	19	0.42	66.6 +0.0 -1.0	11.4	3.5	36.5	51.6	7.9	50.8 ±0.2	3x 7	63	59.5
5320	22.2	0.26	50	18.5 ±0.2	4	39	33	14	-	-	51.5	47
1018	25.4	0.57	75 +0.0 -1.0	13.8	5.9	44.5	53.3	7.9	60.3 ±0.2	3x 7	67.1	61.2
1507	25.4	0.40	71.3 +0.0 -1.0	19.3	6.7	44.5	52.9	2	60.4 ±0.2	2x 5.1	72.2	61.3
1028	31.7	1.16	89 +0.0 -1.0	17	7.5	60.0	77.5	9.5	73 ±0.2	3x 7	94.6	87.1
2010	39.7	2.04	101.6 +0.0 -1.0	17.7	8.2	69.8	90		85.7 ±0.2	3x 9	107.7	99.5
4008	50.8	5.1	152.4 +0.0 -1.0	25.7	13.0	101.6	114	12.7	127 ±0.2		139.7	126.7

10	30
170*	250*
35	100
50	130
100	180
	170
170	410

* Other loads available upon request.

LARGE BOTTOM FLANGE

3012	19	0.42	66.6 +0.0 -1.0	65.1	4.7	36.5	-	7.9	50.8 ±0.2	3x 7	-	55.6
1510	25.4	0.45	75 +0.0 -1.0	72.9	6.7	44.5	-	7.9	60.3 ±0.2	3x 7	-	60.4
1032	31.7	1.02	89 +0.0 -1.0	95.3	7.7	60.0	-	9.5	73 ±0.2	3x 7	-	84.9

10	35
50	130
100	200

PLAIN BODY

3009	19	0.26	-	9.5	4.7	36.5					65.1	55.6
1016	25.4	0.38	-	11.9	6.3	44.5					70.6	58.7
1508	25.4	0.38	-	12.5	6.7	44.5					72.9	60.4
1026	31.7	0.86	-	10.4	7.7	60.0					95.3	84.9
2008	39.7	1.46	-	12.7	9.1	69.8					107.6	94.9
4006	50.8	4.2	-	13	13	101.6					139.7	126.7

10	35
35	140
50	130
100	200
	190
170	410

SMALL TOP FLANGE

3010	19	0.30	45 +0.0 -1.0	11.4	3.5	36.5	51.6	7.9			63	59.5
1017	25.4	0.44	50 +0.0 -1.0	13.8	5.9	44.5	53.3				67.1	61.2
1509	25.4	0.39	56 +0.0 -1.0	19.3	6.7	44.5	52.9	2			72.2	61.3
1027	31.7	0.99	75 +0.0 -1.0	17	7.5	60.0	77.5	9.5			94.6	87.1
2009	39.7	1.8		17.7	8.2	69.8	90				107.7	99.5
4007	50.8	4.4	114.3 +0.0 -1.0	25.7	13	101.6	114	12.7			139.7	126.7

10	30
35	100
50	130
100	180
	170
170	410

To order, specify REF N° and TYPE, i.e. 3011-13.

General Spring Rating Tolerance ±10%
General Tolerance unless stated ±0.3mm

TUFF SERIES HEAVY DUTY UNITS

Always *TUFF SERIES* Heavy Duty units are built to provide a long working life and to withstand harsh conditions.

They have a solid machined body with chrome steel bearings and incorporate both dust seal and dirt exit hole (except No. 0519).

They provide a higher load capacity than standard units.

Solid steel housing for attachment purposes, but not shock loading.

All units are machined using CNC machines from one piece of steel, therefore flanges and threads are integral.

ALSO AVAILABLE

All patterns (i.e.: 21,22,23 and 24) of ref nos 0519, 3019 and 1019 are available with a nylon main ball (Type 14) ideal for light load and reduced marking applications.

TUFF HEAVY DUTY 21

Features: Plain solid machined body.

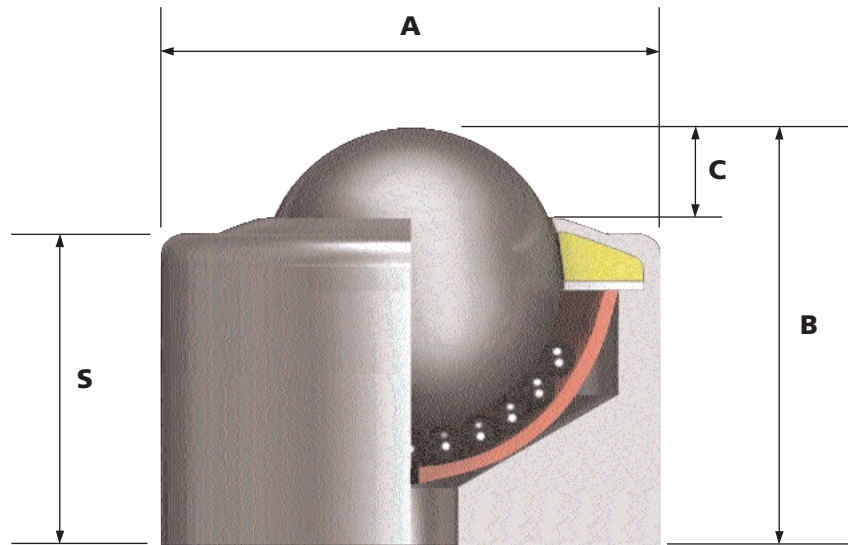

TUFF HEAVY DUTY 22

Features: Flange fixing either by using rivets or screws.

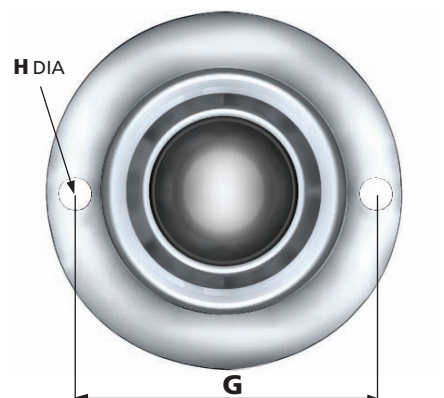
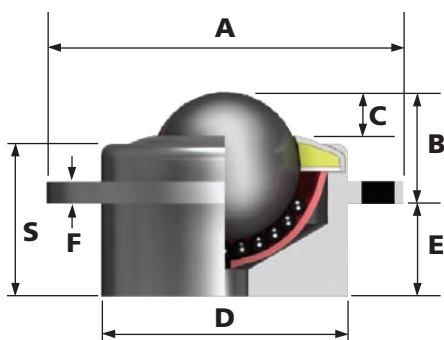

TUFF HEAVY DUTY 23

Features: Bolt, drilled hole fixing. Maximum tightening torques range from 10Nm for M6 to 20Nm for M12.

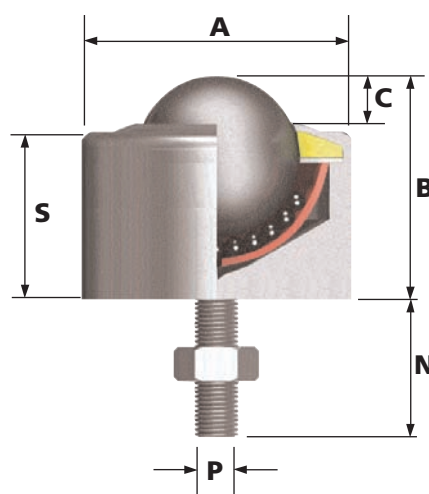

TUFF HEAVY DUTY 24

Features: Bottom flange fixing either by using rivets or screws. Drilled hole fixing.

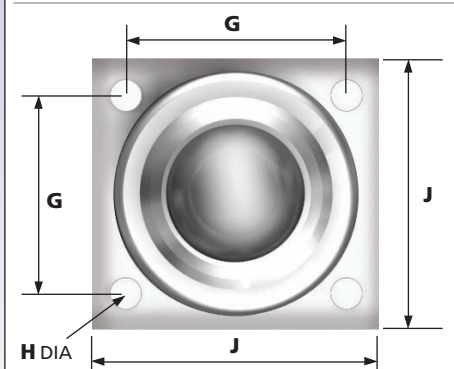
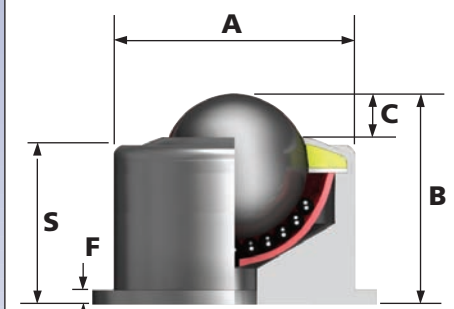

REF No.	BALL SIZE (mm)	WEIGHT (KGS)	DIMENSIONS (mm)											DYNAMIC LOAD CAPACITY (kg)	
			A Maximum Diameter	B Working Height of Ball	C Ball Exposure above Outer Ring	D Body Diameter	E Distance Under Flange to Base	F Flange Thickness	G Centres of Fixing Holes	H Hole Diameter of Fixing Holes	J Major Flange Size	N Length of Thread	P Thread Size	S Base to Top of Body	TYPE 13 Carbon Steel Bearings, Zinc Plated Pressings

0519-21	12.7	0.036	20	20	2	-	-	-	-	-	-	-	-	17	25	25
0519-22		0.051	32	12		20	8	4	26 ±0.2	3	-	-	-	17		
0519-23		0.042	20	20		-	-	-	-	-	-	28	M6	17		
0519-24		0.096	20	25		-	-	6	24 ±0.2	6.5	35	-	-	22		

3019-21	19	0.120	30	30	4	-	-	-	-	-	-	-	-	26	50	50
3019-22		0.168	50	14		30	16	5	40 ±0.2	5	-	-	-	26		
3019-23		0.124	30	30		-	-	-	-	-	-	25	M8	26		
3019-24		0.220	30	35		-	-	6	31 ±0.2	7	44.5	-	-	31		

Confirmar dimensiones diámetro cuerpo (D)

1019-21	25.4	0.177	35	35	7	-	-	-	-	-	-	-	-	28	125	125
1019-22		0.282	60	20		40	15	5	49 ±0.2	5	-	-	-	28		
1019-23		0.190	35	35		-	-	-	-	-	-	40	M8	28		
1019-24		0.294	35	40		-	-	6	35 ±0.2	7	50	-	-	33		

1029-21	31.7	0.486	50	45	8	-	-	-	-	-	-	-	-	37	250	250
1029-22		0.584	75	24		50	21	5	62.5 ±0.2	5	-	-	-	37		
1029-23		0.500	50	45		-	-	-	-	-	-	40	M10	37		
1029-24		0.740	50	50		-	-	8	49 ±0.2	7	63.45	-	-	42		

2019-21	39.7	0.850	60	55	9	-	-	-	-	-	-	-	-	46	500	250
2019-22		0.960	84	27		60	28	5	72 ±0.2	6	-	-	-	46		
2019-23		0.900	60	55		-	-	-	-	-	-	50	M12	46		
2019-24		1.350	60	60		-	-	10	60 ±0.2	7	80	-	-	51		

To order, specify REF N° and TYPE, i.e. 0519-21-13.

General Tolerance unless stated ±0.3mm



FIXING CLIPS

Always provide a complete range of fixing clips designed specially for use with their ball transfer units.

They lock the unit securely in position without the need for special tools or machinery.

Some standard clips are described here. Special designs can also be provided, please ask for details.

The effectiveness and security of ball units attached by means of fixing clips can be influenced by size of fixing holes, table thickness and ball unit tolerances.

CL11 (stock item)

Available in three sizes only to suit ball units with body diameters of 36mm, 45mm and 62mm.

CL12 (made to order)

This clip will fit under the flange of any of our ball units that have parallel sides. If any particular size of clip is not in stock there may be a minimum order charge. Fixing hole sizes on application.

On certain units it is possible to machine a recess to retain the clip in the body of the ball unit. These units must have a solid steel body, are not stock items and are only manufactured to specific orders.

CL13 (stock item)

These are to be used with ball units with a body diameter of 24mm only.

CL14 (stock item)

Stocked for body diameter of 24mm, 36mm, 45mm and 62mm. This clip was designed for fixing ball units from the top face of a ball platform. The clip can also be used for fixing the ball unit from underneath the ball platform if clip CL11 is not suitable. The preferred table top material thickness for maximum effectiveness of the CL14 range of clips is 2mm to 4mm. The CL14 fixing clips can be used for thicker materials with a slight reduction in clip effectiveness. For maximum clip effectiveness the seating hole size should be on the minimum tolerance and the table top material thickness should be 4mm. Please see page 17 for seating hole sizes

CL14 fixing clips must be placed into the seating hole first, before the ball unit is fitted.

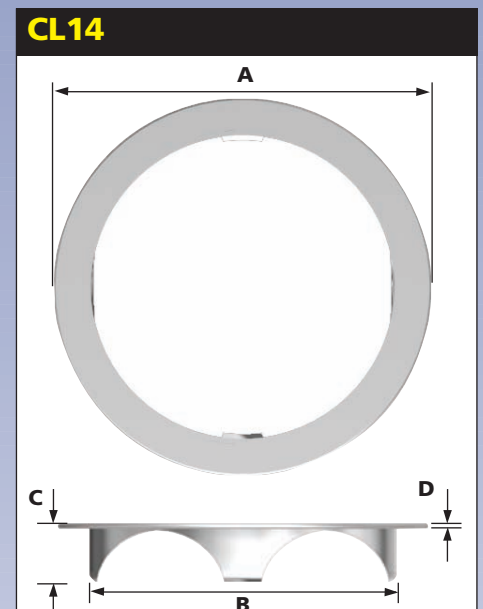
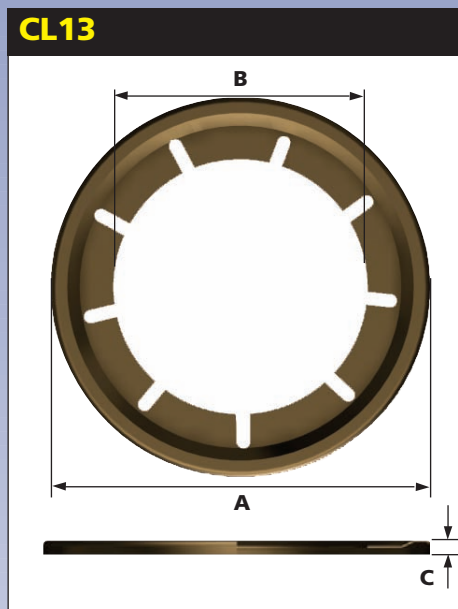
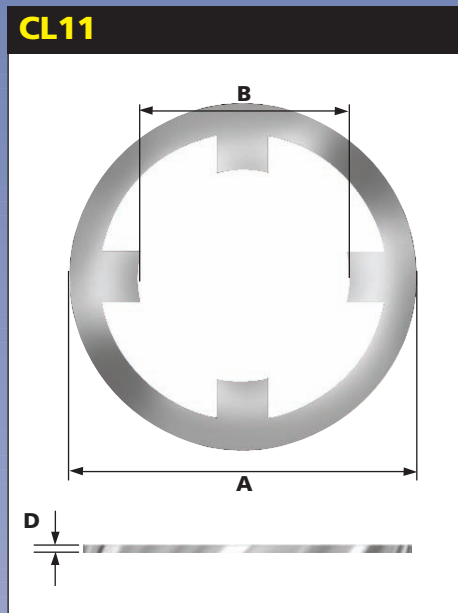
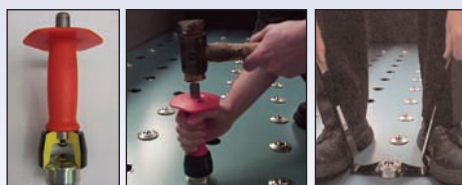
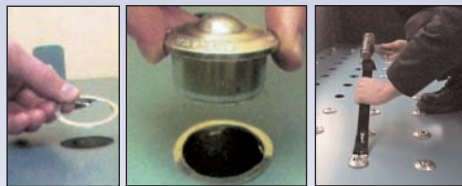

CL15 (made to order)

A circlip type clip used mainly for solid machined body units. The circlip is fitted from underneath the ball unit and is available in many sizes.

Ball units with circlip grooves are not ex stock items. The standard circlip is self colour spring steel, but plated circlips can be offered where corrosion resistance is required.

FITTING CL12 AND CL14 FIXING CLIPS

When fitting ball units with CL12 or CL14 fixing clips, do not strike the load ball to press the unit into position.

Instead, apply an even force onto the ball unit's body using a tube or similar tool.

Installation and removal tools can be supplied to ensure the correct installation of ball transfer units for the CL12 and CL14 fixing clip range. Details of the installation and removal tools are available upon request.

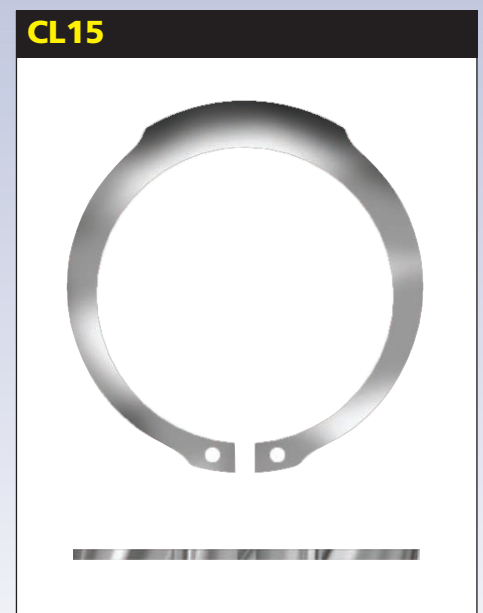

REF No																											
CL11		<table border="1"> <thead> <tr> <th>Ref No.</th> <th>Flange diameter A</th> <th>Inside diameter B</th> <th>Material Thickness D</th> </tr> </thead> <tbody> <tr> <td>CL11-22</td> <td>Ø71.1</td> <td>Ø35.9</td> <td>0.7</td> </tr> <tr> <td>CL11-30</td> <td>Ø71.1</td> <td>Ø44.9</td> <td>0.7</td> </tr> <tr> <td>CL11-45</td> <td>Ø72.6</td> <td>Ø61.2</td> <td>0.7</td> </tr> </tbody> </table>	Ref No.	Flange diameter A	Inside diameter B	Material Thickness D	CL11-22	Ø71.1	Ø35.9	0.7	CL11-30	Ø71.1	Ø44.9	0.7	CL11-45	Ø72.6	Ø61.2	0.7									
		Ref No.	Flange diameter A	Inside diameter B	Material Thickness D																						
CL11-22	Ø71.1	Ø35.9	0.7																								
CL11-30	Ø71.1	Ø44.9	0.7																								
CL11-45	Ø72.6	Ø61.2	0.7																								
<table border="1"> <thead> <tr> <th colspan="4">CL11 CLIP TO BE USED WITH THE FOLLOWING BALL UNITS</th> </tr> <tr> <th>CL11-22</th> <th>CL11-30</th> <th colspan="2">CL11-45</th> </tr> </thead> <tbody> <tr> <td>522-0, 522-4 and 522-6 (pages 16 & 17)</td> <td>530-0, 530-4 and 530-6 (pages 16 & 17)</td> <td colspan="2">545-0, 545-4 and 545-6 (pages 16 & 17)</td> </tr> <tr> <td>800-22 and 810-22 (pages 18 & 19)</td> <td>800-30, 805-30 806-30, 807-30 and 810-30 (pages 18 & 19)</td> <td colspan="2">800-45, 80545 and 810-45 (pages 18 & 19)</td> </tr> </tbody> </table>		CL11 CLIP TO BE USED WITH THE FOLLOWING BALL UNITS				CL11-22	CL11-30	CL11-45		522-0, 522-4 and 522-6 (pages 16 & 17)	530-0, 530-4 and 530-6 (pages 16 & 17)	545-0, 545-4 and 545-6 (pages 16 & 17)		800-22 and 810-22 (pages 18 & 19)	800-30, 805-30 806-30, 807-30 and 810-30 (pages 18 & 19)	800-45, 80545 and 810-45 (pages 18 & 19)											
CL11 CLIP TO BE USED WITH THE FOLLOWING BALL UNITS																											
CL11-22	CL11-30	CL11-45																									
522-0, 522-4 and 522-6 (pages 16 & 17)	530-0, 530-4 and 530-6 (pages 16 & 17)	545-0, 545-4 and 545-6 (pages 16 & 17)																									
800-22 and 810-22 (pages 18 & 19)	800-30, 805-30 806-30, 807-30 and 810-30 (pages 18 & 19)	800-45, 80545 and 810-45 (pages 18 & 19)																									
CL12		<table border="1"> <thead> <tr> <th colspan="4">CL12 CLIP TO BE USED WITH THE FOLLOWING BALL UNITS</th> </tr> </thead> <tbody> <tr> <td>1007 (Pages 8 & 9)</td> <td>515-0, 515-4, 515-6 522-0, 522-4, 522-6 530-0, 530-4, 530-6 545-0, 545-4, 545-6 (Pages 16 & 17)</td> <td>6025-2 and 6025-4 (Pages 20 & 21)</td> <td>7104, 7124 7125, 7152 and 7171 (Pages 22 & 23)</td> </tr> <tr> <td>0519-22, 3019-22 1019-22, 1029-22 and 2019-22 (Pages 28 & 29)</td> <td>810-15, 800-22 810-22, 800-30 805-30, 810-30 800-45, 805-45 806-30, 807-30 810-45 and 800-60 (Pages 18 & 19)</td> <td>3010, 3011, 1017 1018, 1509, 1507 1027, 1028, 2009 2010, 4007 and 4008 (Pages 26 & 27)</td> <td></td> </tr> </tbody> </table>	CL12 CLIP TO BE USED WITH THE FOLLOWING BALL UNITS				1007 (Pages 8 & 9)	515-0, 515-4, 515-6 522-0, 522-4, 522-6 530-0, 530-4, 530-6 545-0, 545-4, 545-6 (Pages 16 & 17)	6025-2 and 6025-4 (Pages 20 & 21)	7104, 7124 7125, 7152 and 7171 (Pages 22 & 23)	0519-22, 3019-22 1019-22, 1029-22 and 2019-22 (Pages 28 & 29)	810-15, 800-22 810-22, 800-30 805-30, 810-30 800-45, 805-45 806-30, 807-30 810-45 and 800-60 (Pages 18 & 19)	3010, 3011, 1017 1018, 1509, 1507 1027, 1028, 2009 2010, 4007 and 4008 (Pages 26 & 27)														
		CL12 CLIP TO BE USED WITH THE FOLLOWING BALL UNITS																									
1007 (Pages 8 & 9)	515-0, 515-4, 515-6 522-0, 522-4, 522-6 530-0, 530-4, 530-6 545-0, 545-4, 545-6 (Pages 16 & 17)	6025-2 and 6025-4 (Pages 20 & 21)	7104, 7124 7125, 7152 and 7171 (Pages 22 & 23)																								
0519-22, 3019-22 1019-22, 1029-22 and 2019-22 (Pages 28 & 29)	810-15, 800-22 810-22, 800-30 805-30, 810-30 800-45, 805-45 806-30, 807-30 810-45 and 800-60 (Pages 18 & 19)	3010, 3011, 1017 1018, 1509, 1507 1027, 1028, 2009 2010, 4007 and 4008 (Pages 26 & 27)																									
<p>CL12 fixing clip sizes available upon request</p>																											
CL13		<table border="1"> <thead> <tr> <th>Ref No.</th> <th>Flange diameter A</th> <th>Inside diameter B</th> <th>Length C</th> </tr> </thead> <tbody> <tr> <td>CL13-15</td> <td>Ø41.4</td> <td>Ø23.4</td> <td>3.2</td> </tr> </tbody> </table>	Ref No.	Flange diameter A	Inside diameter B	Length C	CL13-15	Ø41.4	Ø23.4	3.2																	
		Ref No.	Flange diameter A	Inside diameter B	Length C																						
CL13-15	Ø41.4	Ø23.4	3.2																								
<p>The CL13-15 fixing clip can be used with the 515-0, 515-4 and 515-6 ball units (pages 16-17) and also the 810-15 ball unit (pages 18 and 19).</p>																											
CL14	 <p>Please see page 17 for seating hole sizes</p>	<table border="1"> <thead> <tr> <th>Ref No.</th> <th>Flange diameter A</th> <th>Body outside diameter B</th> <th>Length C</th> <th>Material Thickness D</th> </tr> </thead> <tbody> <tr> <td>CL14-15</td> <td>Ø30.9</td> <td>Ø24.7</td> <td>6.0</td> <td>0.3</td> </tr> <tr> <td>CL14-22</td> <td>Ø44.5</td> <td>Ø36.7</td> <td>7.0</td> <td>0.3</td> </tr> <tr> <td>CL14-30</td> <td>Ø54.9</td> <td>Ø45.7</td> <td>7.0</td> <td>0.3</td> </tr> <tr> <td>CL14-45</td> <td>Ø74.0</td> <td>Ø62.7</td> <td>7.0</td> <td>0.3</td> </tr> </tbody> </table>	Ref No.	Flange diameter A	Body outside diameter B	Length C	Material Thickness D	CL14-15	Ø30.9	Ø24.7	6.0	0.3	CL14-22	Ø44.5	Ø36.7	7.0	0.3	CL14-30	Ø54.9	Ø45.7	7.0	0.3	CL14-45	Ø74.0	Ø62.7	7.0	0.3
		Ref No.	Flange diameter A	Body outside diameter B	Length C	Material Thickness D																					
CL14-15	Ø30.9	Ø24.7	6.0	0.3																							
CL14-22	Ø44.5	Ø36.7	7.0	0.3																							
CL14-30	Ø54.9	Ø45.7	7.0	0.3																							
CL14-45	Ø74.0	Ø62.7	7.0	0.3																							
<table border="1"> <thead> <tr> <th colspan="4">CL14 CLIP TO BE USED WITH THE FOLLOWING BALL UNITS</th> </tr> <tr> <th>CL14-15</th> <th>CL14-22</th> <th>CL14-30</th> <th>CL14-45</th> </tr> </thead> <tbody> <tr> <td>515-0, 515-4 and 515-6 (pages 16 & 17)</td> <td>522-0, 522-4 and 522-6 (pages 16 & 17)</td> <td>530-0, 530-4 and 530-6 (pages 16 & 17)</td> <td>545-0, 545-4 and 545-6 (pages 16 & 17)</td> </tr> <tr> <td>7104 (pages 22 & 23)</td> <td>800-22, 810-22 (pages 18 & 19)</td> <td>800-30, 805-30, 806-30 807-30 and 810-30 (pages 18 & 19)</td> <td>800-45, 805-45 and 810-45 (pages 18 & 19)</td> </tr> <tr> <td>810-15 (pages 18 & 19)</td> <td></td> <td>1017, 1018, 1507 and 1509 (pages 26 & 27)</td> <td></td> </tr> <tr> <td></td> <td></td> <td>7124 (pages 22 & 23)</td> <td></td> </tr> </tbody> </table>		CL14 CLIP TO BE USED WITH THE FOLLOWING BALL UNITS				CL14-15	CL14-22	CL14-30	CL14-45	515-0, 515-4 and 515-6 (pages 16 & 17)	522-0, 522-4 and 522-6 (pages 16 & 17)	530-0, 530-4 and 530-6 (pages 16 & 17)	545-0, 545-4 and 545-6 (pages 16 & 17)	7104 (pages 22 & 23)	800-22, 810-22 (pages 18 & 19)	800-30, 805-30, 806-30 807-30 and 810-30 (pages 18 & 19)	800-45, 805-45 and 810-45 (pages 18 & 19)	810-15 (pages 18 & 19)		1017, 1018, 1507 and 1509 (pages 26 & 27)				7124 (pages 22 & 23)			
CL14 CLIP TO BE USED WITH THE FOLLOWING BALL UNITS																											
CL14-15	CL14-22	CL14-30	CL14-45																								
515-0, 515-4 and 515-6 (pages 16 & 17)	522-0, 522-4 and 522-6 (pages 16 & 17)	530-0, 530-4 and 530-6 (pages 16 & 17)	545-0, 545-4 and 545-6 (pages 16 & 17)																								
7104 (pages 22 & 23)	800-22, 810-22 (pages 18 & 19)	800-30, 805-30, 806-30 807-30 and 810-30 (pages 18 & 19)	800-45, 805-45 and 810-45 (pages 18 & 19)																								
810-15 (pages 18 & 19)		1017, 1018, 1507 and 1509 (pages 26 & 27)																									
		7124 (pages 22 & 23)																									
CL15		<table border="1"> <thead> <tr> <th colspan="3">CL15 CLIP TO BE USED WITH THE FOLLOWING BALL UNITS</th> </tr> </thead> <tbody> <tr> <td>1004 (pages 8 & 9)</td> <td>7104, 7124, 7125 7152 and 7171 (pages 22 & 23)</td> <td>0519-22, 3019-22, 1019-22 1029-22 and 2019-22 (pages 28 & 29)</td> </tr> <tr> <td>810-15, 800-22, 810-22 800-30, 805-30, 810-30 800-45, 805-45, 810-45 and 800-60 (pages 18 and 19)</td> <td>3010, 3011, 1017, 1018 1509, 1507, 1027, 1028 2009, 2010, 4007 and 4008 (pages 26 and 27)</td> <td></td> </tr> </tbody> </table>	CL15 CLIP TO BE USED WITH THE FOLLOWING BALL UNITS			1004 (pages 8 & 9)	7104, 7124, 7125 7152 and 7171 (pages 22 & 23)	0519-22, 3019-22, 1019-22 1029-22 and 2019-22 (pages 28 & 29)	810-15, 800-22, 810-22 800-30, 805-30, 810-30 800-45, 805-45, 810-45 and 800-60 (pages 18 and 19)	3010, 3011, 1017, 1018 1509, 1507, 1027, 1028 2009, 2010, 4007 and 4008 (pages 26 and 27)																	
		CL15 CLIP TO BE USED WITH THE FOLLOWING BALL UNITS																									
1004 (pages 8 & 9)	7104, 7124, 7125 7152 and 7171 (pages 22 & 23)	0519-22, 3019-22, 1019-22 1029-22 and 2019-22 (pages 28 & 29)																									
810-15, 800-22, 810-22 800-30, 805-30, 810-30 800-45, 805-45, 810-45 and 800-60 (pages 18 and 19)	3010, 3011, 1017, 1018 1509, 1507, 1027, 1028 2009, 2010, 4007 and 4008 (pages 26 and 27)																										
<p>Ball units with circlip grooves are available on request CL15 fixing clip sizes available upon request</p>																											

To order, specify REF N° i.e. CL11-22.
For CL12 and CL15 clips specify REF N° and ball unit REF N° i.e. CL12,1007.

TEE BLOCKS, DIE TABLES

TEE BLOCKS

Single Minute Tool and Die Changing

Our comprehensive range of tee blocks and spring loaded ball transfer units, set into the bed of your power press or machine tool, will allow effortless positioning of tooling but still allow rigid clamping.

We supply tee blocks for both standard and non-standard tee slots the length, pitch, ball height etc. being dependant on tool weight and profile.

Other sizes available on request.

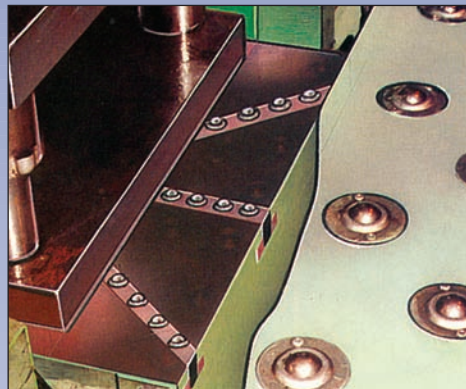

QUICK CHANGE DIE TABLES

For all types of moulding and stamping applications.

They allow quick, easy tool changing with storage close to the machine. All tables are fully guarded. Access to the machine via a lift-up gate if required.

Custom designed to your specific requirements, installation is carried out by our engineers.

NOTE - safety rails should be fitted where there is the possibility of loads rolling off.

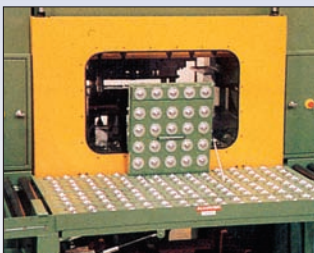

TEE BLOCKS

Tee blocks can be designed and manufactured to suit particular applications. See pages 24 & 25 for our range of Die Lifter ball units.

Standard Tee Block Slot Proportions

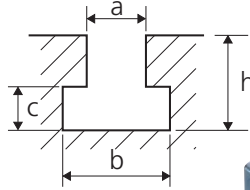

DIN 650

a	b	c	h
22	37	16	38
24	42	18	42
28	46	20	48
36	56	25	61



TEE BLOCK SECURED BY SOCKET SCREW

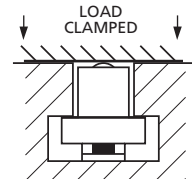
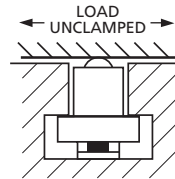
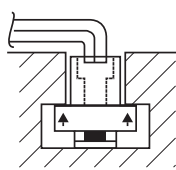

QUICK CHANGE DIE TABLES





**ALWAYSE ENGINEERING
BIRMINGHAM
ENGLAND**

ALWAYSE

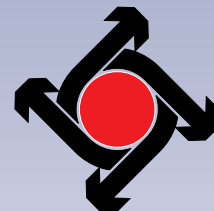

ALWAYSE ENGINEERING LIMITED

MILLER STREET BIRMINGHAM B6 4NF ENGLAND

Telephone: 0121 380 4700 (International): 44 121 380 4700

Fax: 0121 380 4701 (International): 44 121 380 4701

Home page: www.alwayse.net E-mail: sales@alwayse.co.uk